



OPERATOR & PARTS MANUAL
4 ft wide

Serial # starting at I2032

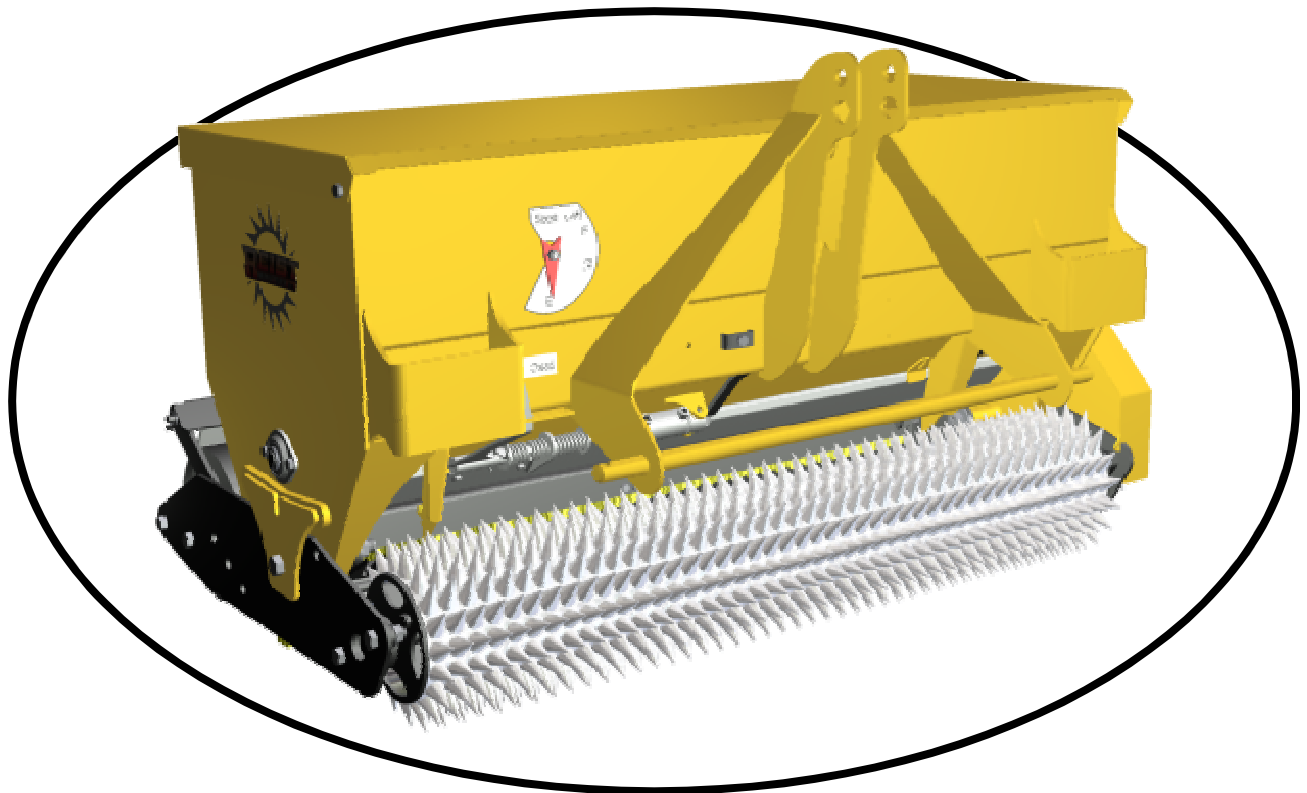

TABLE OF CONTENTS



ITEM	PAGE
INTRODUCTION	2
SAFETY	3
CALIBRATION	4
STANDARD ROLLER ASSEMBLY	5
DOUBLE ROLLER ASSEMBLY	6
STORAGE	7
PARTS	8-16
WARRANTY	17

CONGRATULATIONS!!

Thank you for choosing the **Reist Area Seeder**. We feel confident that this equipment will meet your expectations in workmanship, reliability and performance.

This manual is to assist you with the safe operation of the Area Seeder.

The Reist Area Seeder

Is a versatile piece of equipment to assist you in various primary and over seeding needs.

MODEL NO. _____ **SERIAL NO.** _____.



CAUTION !

1. For proper safe operation we recommend that the tractor be equipped with an approved Roll-Over Protective Structure and Safety Belt.
2. Do not operate an engine in a confined or non-ventilated area.
3. Do not perform any adjustments or repairs with engine running.
4. Always lower 3 PT hitch to ground before performing adjustments or repairs.
5. Do not operate on excessive incline and always be careful when turning on slopes.
6. Never carry passengers on implement or tractor.
7. Never let a child operate machinery.
8. Hydraulic fluid under pressure can cause serious injury. Do Not use your hands to locate leaks.
9. It is the owner's responsibility to make sure that all operators read this manual before operating the equipment.

Calibrating Seed Flow

To calibrate the seed flow rate, you need a weigh scale and small container.

1. Pour seed into seed box. (Each kind of seed needs to be calibrated separately).
2. Insert calibration tray in bottom of seeder on mounts.
3. Set dial to preferred approximate seed rate .
4. With seed flow open, drive the distance of 166 feet. (drive at the same speed as what you are going to drive when seeding).
5. Weigh seed in the calibration tray and multiply by 2. This equals pounds per thousand feet.

Example: 4lb x 2 = 8lb per thousand square ft.

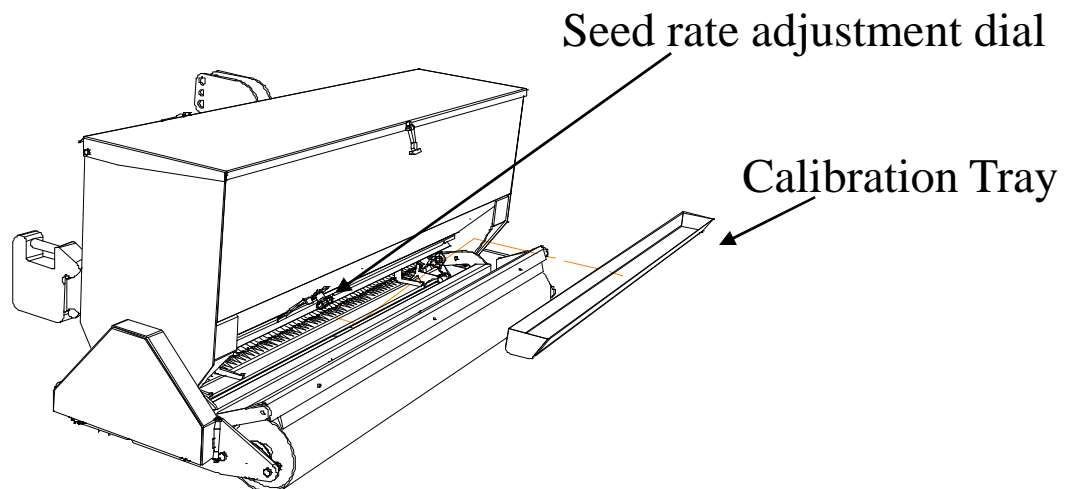

Standard Roller Assembly



Standard

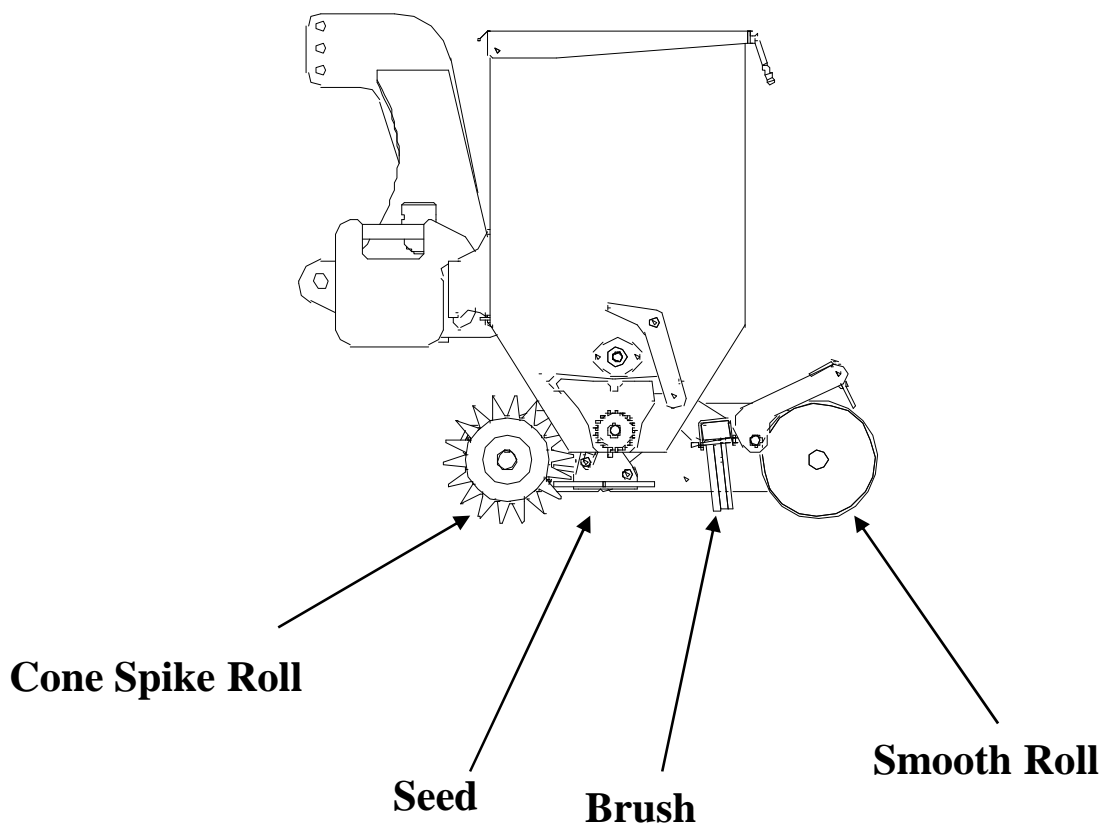

Great for primary and over seeding

For primary seeding, the spike roll breaks up clumps and packs the ground. The seed is then dropped by the seeder and the brush lightly covers the seed. The smooth roll presses the soil to keep the moisture in the ground.

For over seeding the spiked roll pokes small holes into the ground. to moisture, The seed that falls onto the grass is brushed into the holes created by the spike roller. The smooth roll presses down to cover the seed and keep the moisture in.

Double Spike Rolls (Optional)

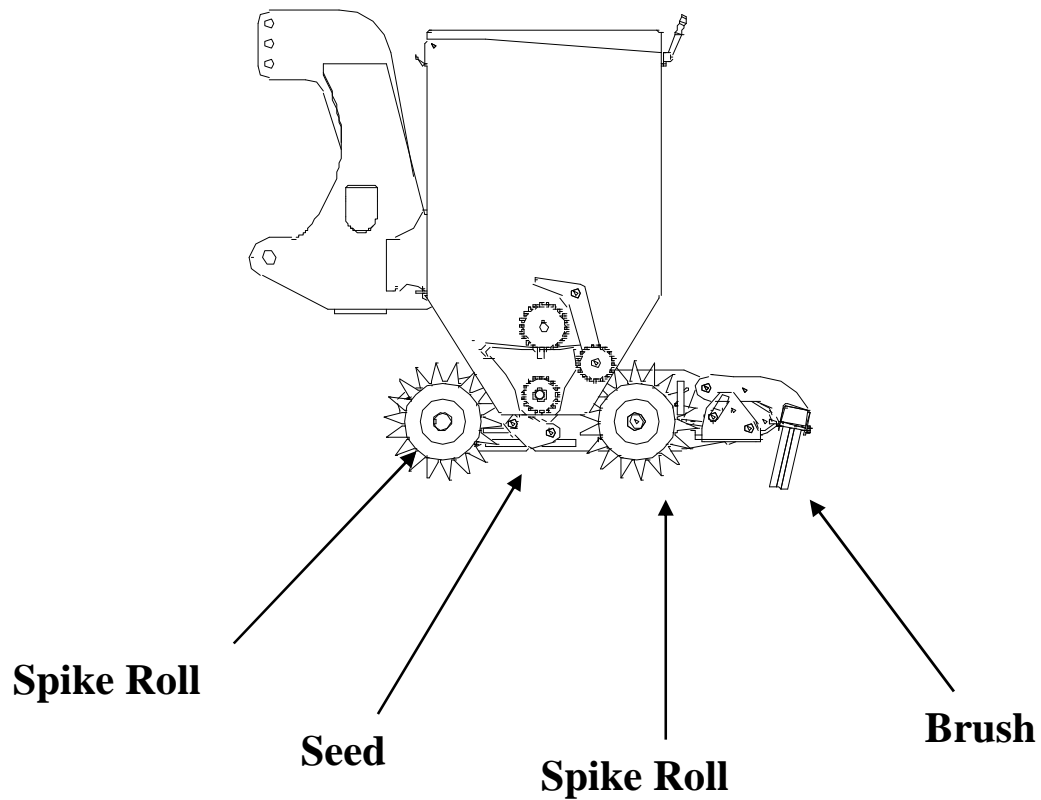

Double the Number of Holes

Over seeding with two spiked rolls has twice the number of holes than the standard roller assembly. Both rolls poke small holes into the ground. Seed that falls onto the grass is brushed into the small holes created by the spike rolls.

Storage



1. Store in dry ventilated area.
2. Set on either concrete pad, some wood blocks, or plywood.
3. Store with hydraulic cylinder piston rod in retracted position.
4. Clean before putting into storage.
5. Touch-up paint as needed.
6. Oil seeder chain

PARTS

Aera Seeder Frame

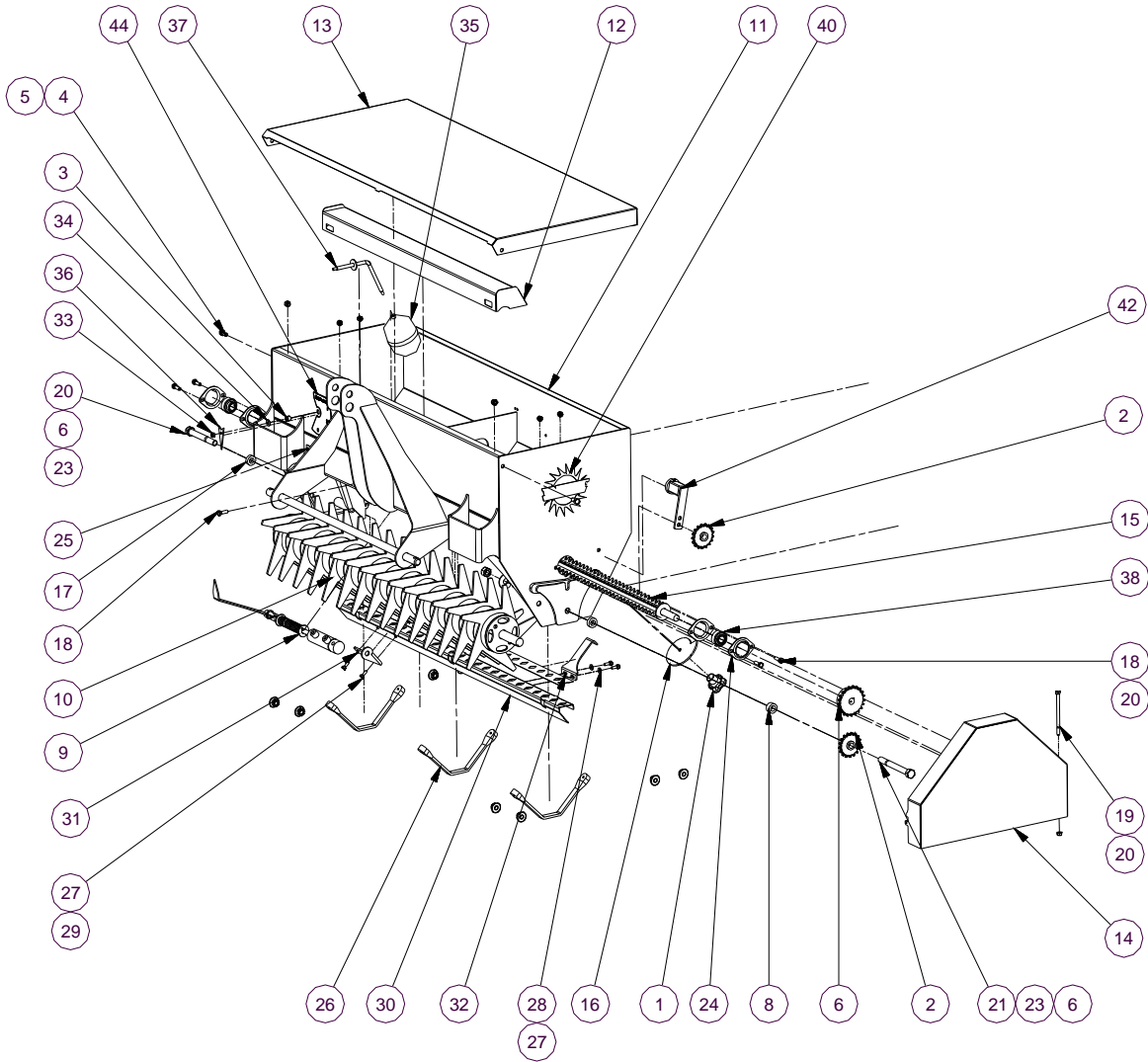

PARTS List



Parts List			
ITEM	QTY	PART NUMBER	DESCRIPTION
1	1	134-022	Knob
2	2	20401708	Idler Sprocket
3	2	315-709	Snap Bushing
4	2	3834	Hex Bolt
5	2	38CLN	Lock Nut
6	1	40B21-3/4	Sprocket
7	1	40RC	Drive Chain (not shown)
8	1	5015	Idler Spacer
9	1	5027	Cylinder Assembly
10	1	508548A	Seed Insert
11	1	508748	Aera Seeder Frame
12	2	5089	Calabration Tray
13	1	509048	Lid
14	1	5091	Shield
15	1	509348	Agitater Shaft
16	1	5099	Seed Rate Dial
17	2	5100	Bushing
18	5	5161	Bolt
19	1	5165	Bolt
20	1	585	5/8x5 NC Bolt
21	1	586	5/8x6 NC bolt
6	4	58F	Flat Washer
23	2	58N	Hex Nut
24	4	MST47	Brg Flange
25	1	Open Closed decal	
26	3	SH-9	Tarp Strap
27	4	1434	Bolt
28	2	14FW	Washer A
29	2	14N	Hex Nut
30	1	508648A	SS Seed Slide
31	1	5094	Cyl Mount
32	1	5098	Slider Stop
33	1	14N	Nut
34	1	14W	Washer
35	1	3305471	Seed Level Ball
36	1	5095	Seed Level Arrow
37	1	5097	Seed Level Rod
38	2	UC204012	Bearing
39	1	Aera Seeder Logo	
40	2	Reist Decal Spiked	
41	1	Slitter Drive Roll	
42	1	SE 15-02	
19	1	C-1037 Hose Clip	Hose Clip
20	6	516N	Hex Nuts

PARTS Cylinder

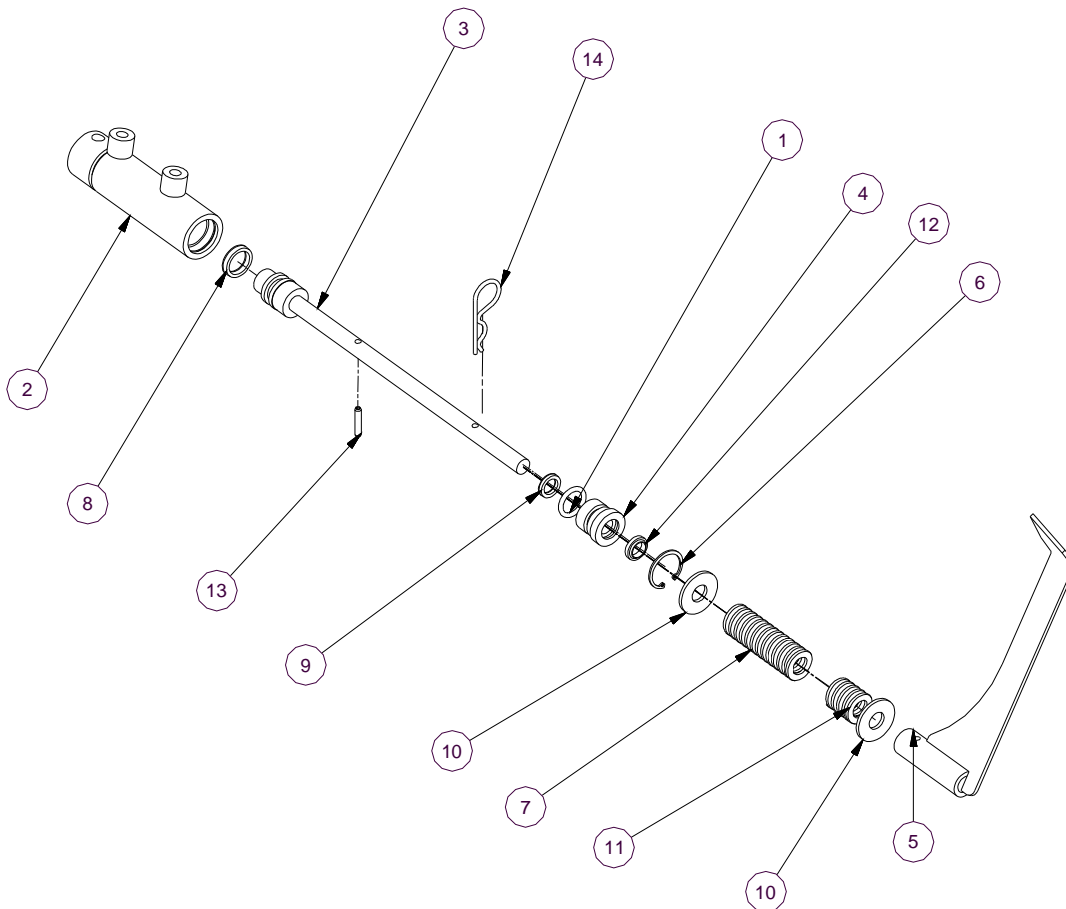

Parts List			
ITEM	QTY	PART NUMBER	DESCRIPTION
1	1	210	O'RING INCH
2	1	5042	Cylinder Tube
3	1	5044	Stem & Piston
4	1	5045	Gland
5	1	5046	Open Shut Indicator
6	1	N5000-106	Internal Snap Ring
7	1	M-17	Long Compression Spring
8	1	U12-0.75-18B	Polly Pack
9	1	U12-0.50-SQB	Polly Pack
10	2	12FL	Washer
11	1	M-12	Short Compression Spring
12	1	ST-50	Wiper
13	1	3161RP	Roll Pin
14	1	383505	Hairpin

PARTS Standard Roll Assembly

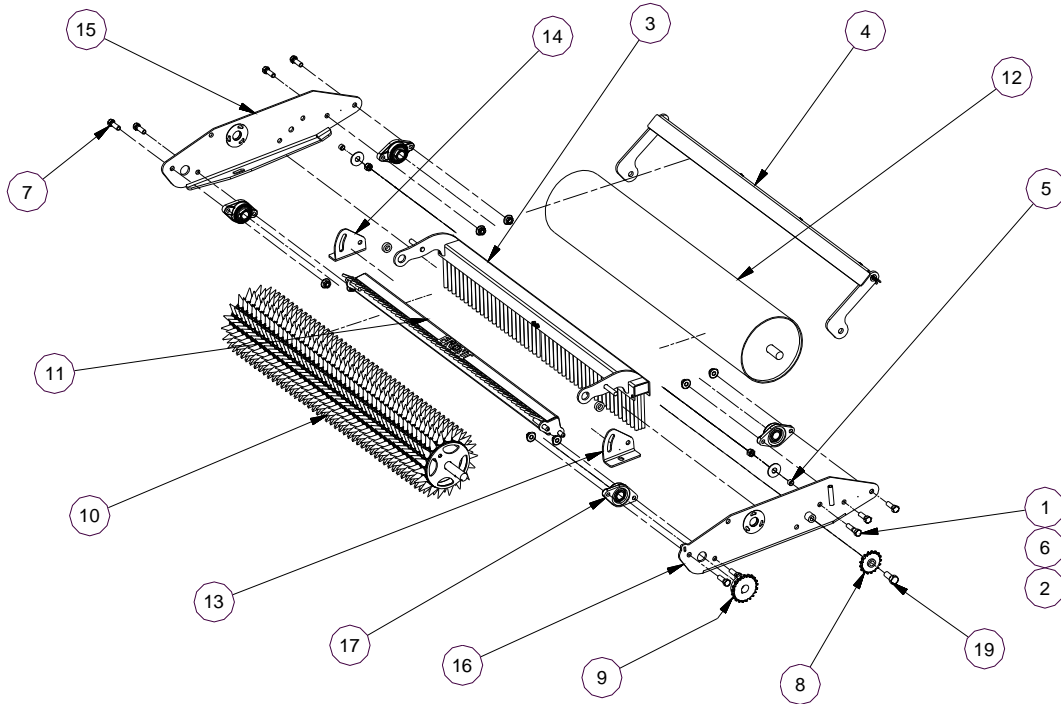

Part numbers with spaces, enter width of Aera Seeder in inches.
 Example: 5027__
 Enter as:502772

Parts List			
ITEM	QTY	PART NUMBER	DESCRIPTION
1	1	12*2	Hex Bolt
2	2	12N	Hex Nut
3	1	5026__	Brush Assembly
4	1	5027__	Smooth Roll Scraper
5	2	MSI-0810-06	Scraper Bushing
6	4	58F	Flat Washer
7	8	1212	Hex Bolt
8	1	20401708	Idler Sprocket
9	1	40B21-1-1/2	Drive Sprocket
10	1	5014__	Spike Drive Roll
11	1	5015__	Front Peg Scraper
12	1	5016__	Smooth Roll
13	1	5052	Peg Scraper Hinge Left
14	1	5053	Peg Scraper Hinge Right
15	1	5103	Side Plate Right S
16	1	5104	Side Plate Left S
17	4	UCFL205-16	Bearing
18	8	12FSLN	Flange Nut
19	1	58112	Hex Bolt

PARTS Spiked Drive Roll



Spiked Drive Roll

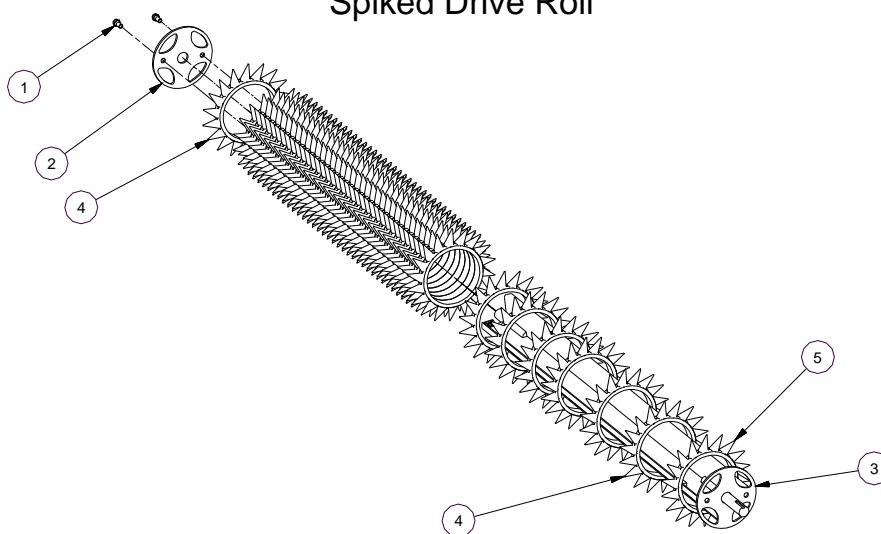

Part numbers with spaces, enter width of Aera Seeder in inches.
 Example: 5027 __
 Enter as:502772

Parts List			
ITEM	QTY	PART NUMBER	DESCRIPTION
1	2	3834	Bolt
2	1	5049	Spike Washer
3	1	5051 __	Drive Roll Light
4	43	5066	Over Seeder Spike machined slanted
5	1	5067	Over Seeder Drive Spike Slanted

PARTS Broom & Scraper



Brush Assembly

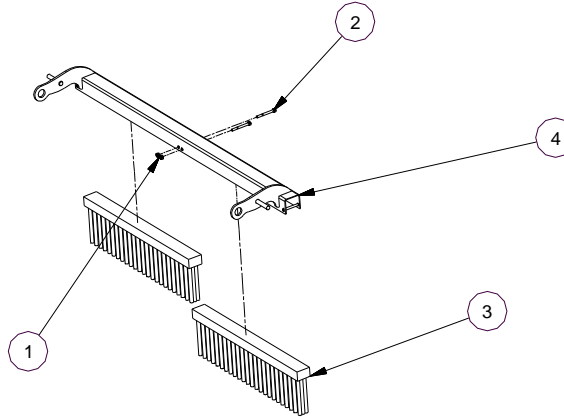

Part numbers with spaces, enter width of Aera Seeder in inches.
 Example: 5027__
 Enter as:502772

Parts List			
ITEM	QTY	PART NUMBER	DESCRIPTION
1	2	1/4 NC Nut	Hex Nut
2	2	14212	Bolt
3	2	2010	Main Frame Brush
4	1	5039__	Aera Seeder Broom Mount

Smooth Roll Scraper

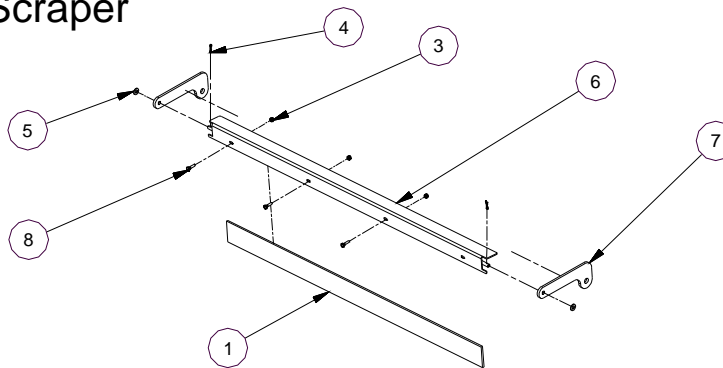

Part numbers with spaces, enter width of Aera Seeder in inches.
 Example: 5027__
 Enter as:502772

Parts List			
ITEM	QTY	PART NUMBER	DESCRIPTION
1	1	1/4x3x__UHMW	UHMW Scraper
3	3	14CLN	Lock Nut
4	2	1834CP	Cotter Pin
5	2	38F	3/8 Flat Washer
6	1	5040__	Smooth Roll Scraper Angle
7	2	5041	Scraper Bracket
8	3	141	Hex Bolt

PARTS Double Spike Roll



Double Spike Roll Assembly

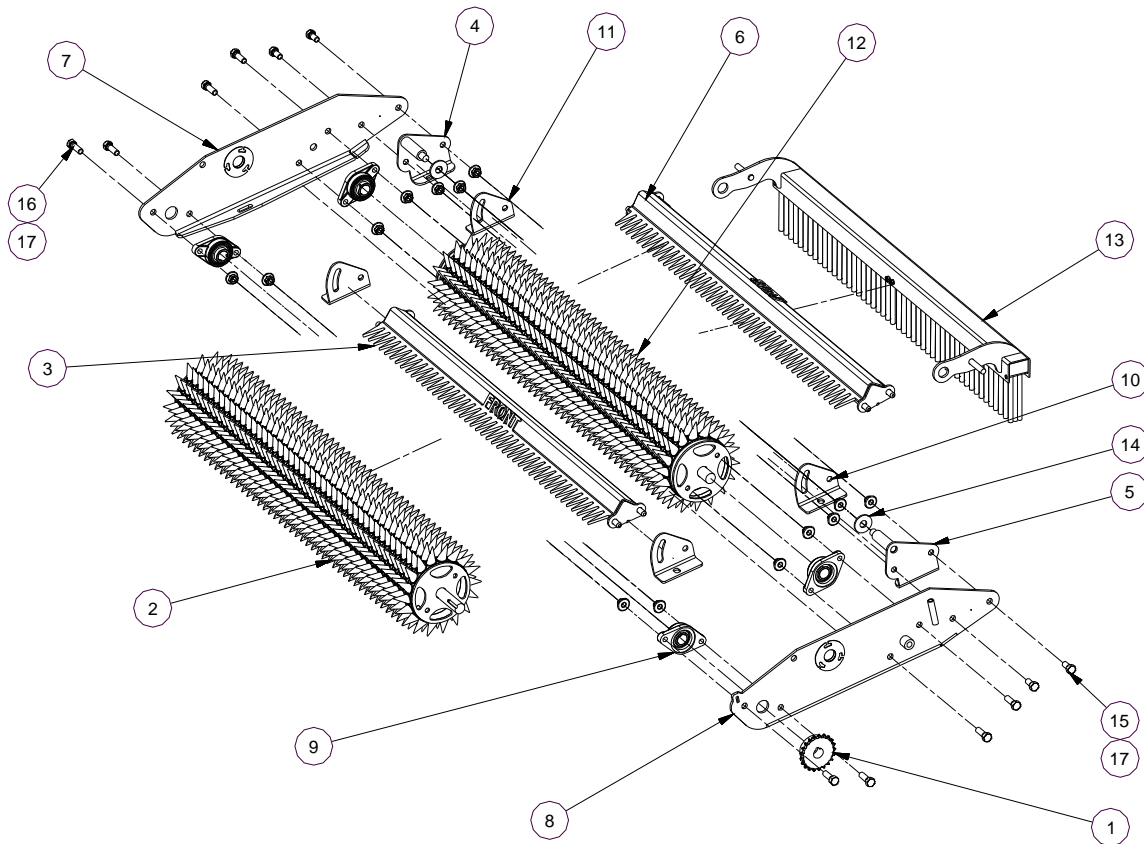

Part numbers with spaces, enter width of Aera Seeder in inches.
 Example: 5027_ _
 Enter as:502772

Parts List			
ITEM	QTY	PART NUMBER	DESCRIPTION
15	4	12*1	Bolt
1	1	40B21-1-1/2	Drive Sprocket
2	1	5014_ _	Spike Drive Roll
3	1	5015_ _	Front Peg Scraper
4	1	5017	Rear Broom Bracket Right
5	1	5018	Rear Broom Bracket Left
6	1	5021_ _	Peg Scraper Rear
13	1	5026_ _	Brush Assembly
10	2	5052	Peg Scraper Hinge Left
11	2	5053	Peg Scraper Hinge Right
12	1	5054_ _	Spike Idler Roll
7	1	5103	Side Plate Right S
8	1	5104	Side Plate Left S
14	2	58F	5/8 Flat Washer
9	4	UCFL205-16	Bearing
16	8	1212	Hex Bolt
17	14	12FSLN	Flange Nut

PARTS Spiked Idler Roll



Spiked Idler Roll

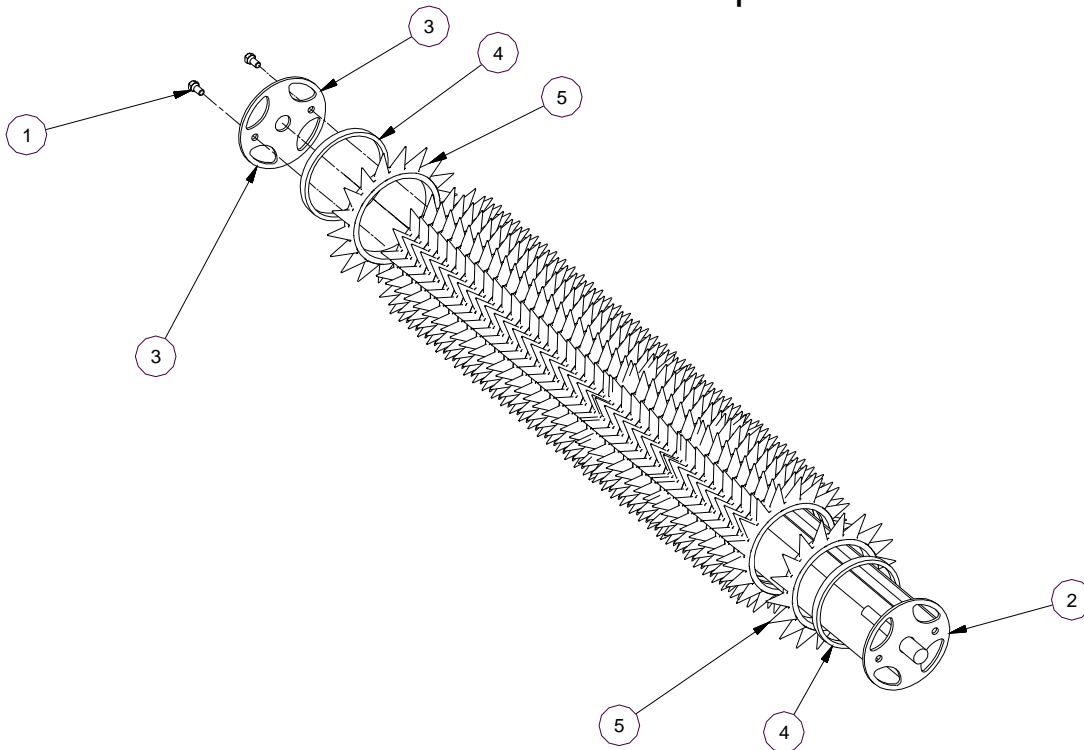

Part numbers with spaces, enter width of Aera Seeder in inches.
 Example: 5027__
 Enter as:502772

Parts List				
ITEM	QTY	PART NUMBER	DESCRIPTION	
1	2	3834	Bolt	
2	1	5048__	Rear Roll Light	
3	1	5049	Spike Washer	
4	2	5051	Rear Spike Spacer	
5	43	5066	Over Seeder Spike machined slanted	

PARTS Double Spike Roll 2nd Position

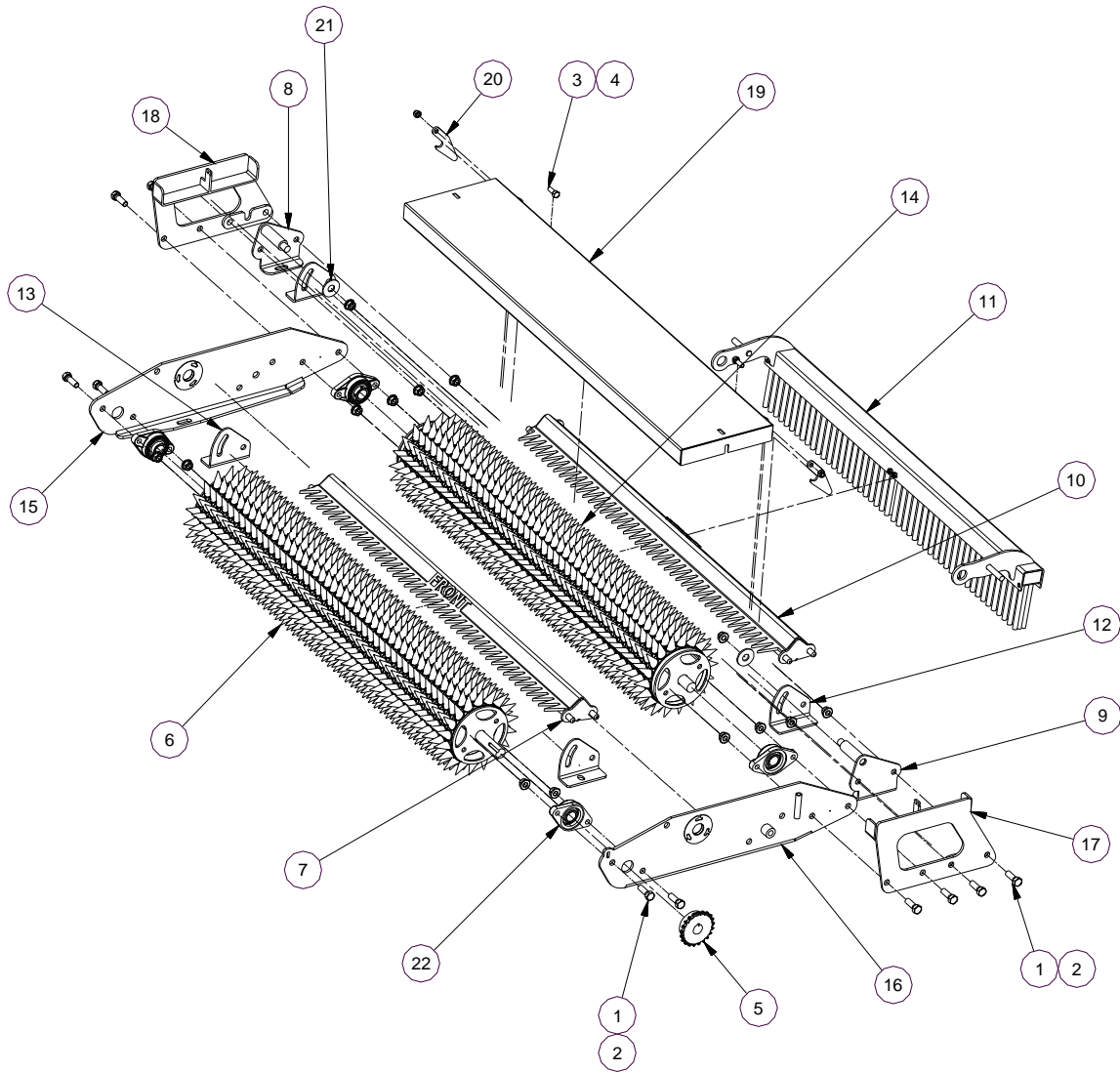

Parts List				Parts List			
ITEM	QTY	PART NUMBER	DESCRIPTION	ITEM	QTY	PART NUMBER	DESCRIPTION
1	12	12112	Bolt	12	2	5052	Peg Scraper Hinge Left
2	14	12FLSN	Flange Nut	13	2	5053	Peg Scraper Hinge Right
3	2	38*1	Bolt	14	1	5054_	Spike Idler Roll
4	2	38CLN	Lock Nut	15	1	5103	Side Plate Right S
5	1	40B21-1-1/2	Drive Sprocket	16	1	5104	Side Plate Left S
6	1	5014_	Spike Drive Roll	17	1	5105	Roll shield Mount
7	1	5015_	Front Peg Scraper	18	1	5106	Roller Shield Mount Right
8	1	5017	Rear Broom Bracket Right	19	1	510748	Roll Shield
9	1	5018	Rear Broom Bracket Left	20	2	5108	Broom Hook
10	1	5021_	Peg Scraper Rear	21	2	58F	5/8 Flat Washer
11	1	5026_	Brush Assembly	22	4	UCFL205-16	Bearing

WARRANTY



All new Reist machinery is warranted to be free from defects in material or workmanship, which may cause failure under normal usage and service when used for the purpose, intended, for a period of 12 months. This warranty applies only to a new Reist product, there being no warranty of any nature in respect to new products that have been modified or altered, repaired, neglected, or used in any way, which, in the opinion of Reist adversely affects its performance.

In the event of failure of a part or parts, and upon inspection, Reist is satisfied that failure is due to defective material or workmanship within 12 calendar months, from the date of delivery to an end user, such defective part or parts will be repaired or replaced by Reist at his business location. It is the responsibility of the buyer, at his expense, to transport the machine or equipment to the manufacturer service shop or, to an authorized service depot or, alternatively, to reimburse Reist for any travel or transportation expense involved in fulfilling this warranty.

When requested by Reist, part or parts shall be returned for inspection, transportation prepaid, to a place designated by Reist. **IN NO EVENT SHALL THE BUYER BE ENTITLED TO RECOVER FOR INCIDENTAL OR CONSEQUENTIAL DAMAGES, INCLUDING, BUT NOT LIMITED TO, LOSS OF PRODUCT, INCONVENIENCE, RENTAL OR REPLACEMENT EQUIPMENT, LOSS OF PROFIT, OR OTHER COMMERCIAL LOSS.**

This warranty becomes void and null if the equipment is modified, breaks down as the result of an accident, is not operated according to manufacturers recommendations, damaged by negligence or if maintenance has not been carried out as specified.

THIS WARRANTY IS NOT TRANSFERABLE

Proof of Purchase

Date of purchase (yyyy mm dd)		Model		Serial #	
Dealer purchased from		City		State or Province	Country
First Name		Last Name		Phone # (include area code)	
Address				State or Province	Country
City	Postal Code	Reist Industries Inc. 100 Union St. Elmira Ontario N3B 2Z2		519-669-1501	

Proof of Purchase

Date of purchase (yyyy mm dd)		Model		Serial #	
Dealer purchased from		City		State or Province	Country
First Name		Last Name		Phone # (include area code)	
Address				State or Province	Country
City	Postal Code	Reist Industries Inc. 100 Union St. Elmira Ontario N3B 2Z2		519-669-1501	

**Reist Industries (Elmira) Ont.
100 Union St., Elmira
Ontario, Canada, N3B 2Z2
www.reistindustries.com**