

48" & 60" In-Fielder

OPERATOR & PARTS MANUAL

Starting at Serial # J2299

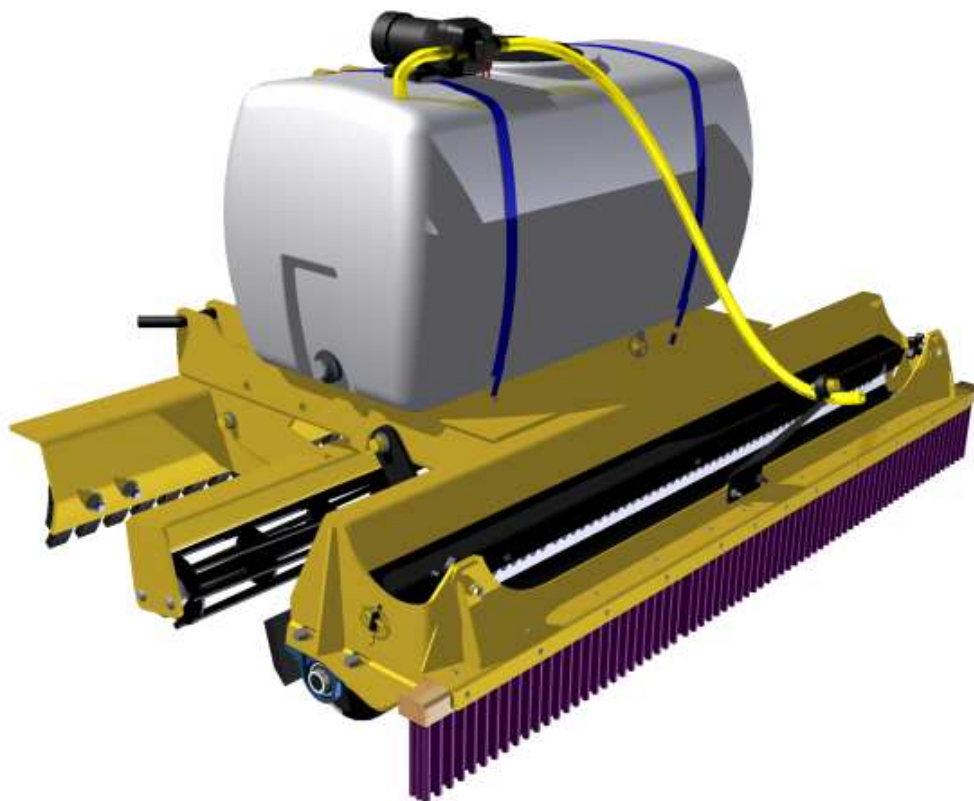

TABLE OF CONTENTS



<u>ITEM</u>	<u>PAGE</u>
INTRODUCTION	3
SAFETY	4 - 5
OPERATION & SETUP INSTRUCTION	6
MAINTENANCE & ADJUSTMENTS	7
PARTS	8 - 10
WARRANTY	11

MODEL No. _____ SERIAL No. _____

CONGRATULATIONS!

Thank you for choosing the **REIST IN-FIELDER**. We feel confident that this equipment will meet your expectations in workmanship, reliability and performance.

This manual is to assist you with the safe operation of the **IN-FIELDER**, This manual also identifies safety decals and information, maintenance intervals and proper storage instructions.

GENERAL SAFETY

CAUTION



1. Careful operation is the best assurance against accidents. It is the owner's responsibility to make sure that all operators have read this manual before operating the equipment.
2. Familiarize yourself with all controls and always be ready to stop equipment quickly in case of emergency.
3. Never let a child operate machinery.
4. Protect yourself by wearing ear protection.
5. Hydraulic fluids under pressure can damage your skin. Do not use your hands to locate leak.

OPERATING SAFETY



CAUTION

1. For proper safe operation we recommend that the tractor be equipped with an approved Roll-Over Protective Structure and Safety Belt.
2. Do not operate an engine in confined or non ventilated area.
3. Do not perform any adjustments or repairs with engine running.
4. Always lower 3 PTH to ground before performing adjustments or repairs.
5. Do not operate on excessive incline and always be careful when turning on slopes.
6. Never carry passengers on implement or tractor.

TRANSPORT SAFETY

CAUTION



1. Use proper safety lights on public roads.
2. Be alert while driving on road and never carry passengers.
3. Road speed should be such to maintain full control over steering and brakes.

Important Setup & Operation Instructions Before Each Use

- Always use proper pin and bushing sizes when attaching infielder to tractor.
- Make sure that bottom 3 PTH arms are level with tractor and stabilized to centre.
- Lower Infielder to ground, putting 3 PTH lever to max. down position.
- Adjust top link until cutting blade makes ground contact by 1/8 inch.
- Adjust rear brushed to make ground contact plus 1/4 inch.
- With 3 PTH lever in max. down position start grooming at 3 to 5 mi/hr.(5 to 8 km/hr).
- Readjust top link to maintain an average cutting depth of 1/8 inch.
- Use alternative driving patterns as you groom.
- If chatter occurs while grooming SLOW DOWN.

Maintenance Before Use

- Make sure all bolts are tight (tighten if necessary)
- Check for worn, bent or broken parts (replace if necessary).
- Grease bushings and bearings as per manual.

PART NUMBERS and DESCRIPTION

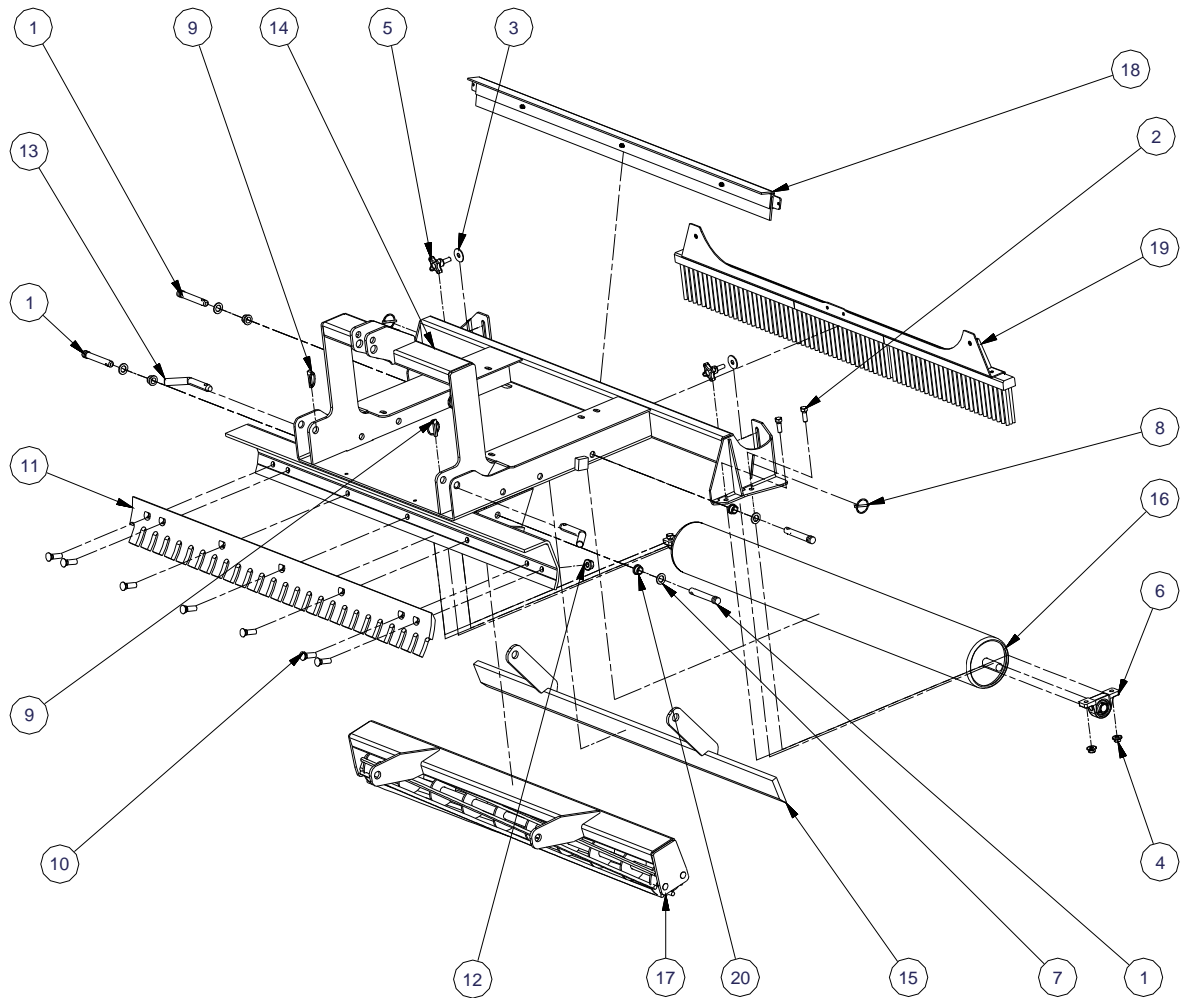

Parts List				Parts List			
ITEM	QTY	PART NUMBER	DESCRIPTION	ITEM	QTY	PART NUMBER	DESCRIPTION
1	4	387503	Top Link Pin	11	1	586_ _VS	Serated Blade
2	4	12112	Hex Bolt	12	7	58FSLN	Flange Nut
3	2	12F	Plain Washer	13	2	CAT1-784	Cat 1 Arm Pin
4	4	12FSLN	Flange Nut	14	1	D_ _ 01	Main Frame Assembly
5	2	135-052	Knob	15	1	D_ _ 02	Leveler Bar
6	2	205100D1	Bearing	16	1	D_ _ 03	Smooth Roll
7	4	34F	Washer	17	1	D_ _ 04	Pulverizer Roll Assembly
8	2	385502	Linch Pin	18	1	D_ _ 05	Smooth Roll Scraper Assembly
9	6	385507	Lynch Pin	19	1	D_ _ 06	Broom Attachment
10	7	5823PB	5/8 x 1-1/2 Plow Bolt	20	4	MFI-1216-10_1	Bushing

PART NUMBERS and DESCRIPTION

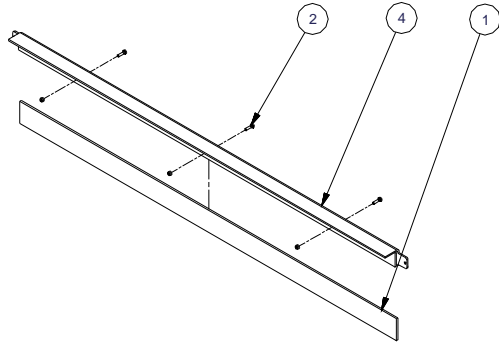

Parts List			
ITEM	QTY	PART NUMBER	DESCRIPTION
1	1	1/4x3x__UHMW	UHMW Scraper
2	3	1/4*1	1/4x1 NC Nut
3	3	1/4CLN	1/4 Lock Nut
4	1	D__07	Smooth Roll Scraper Angle

Broom Assembly

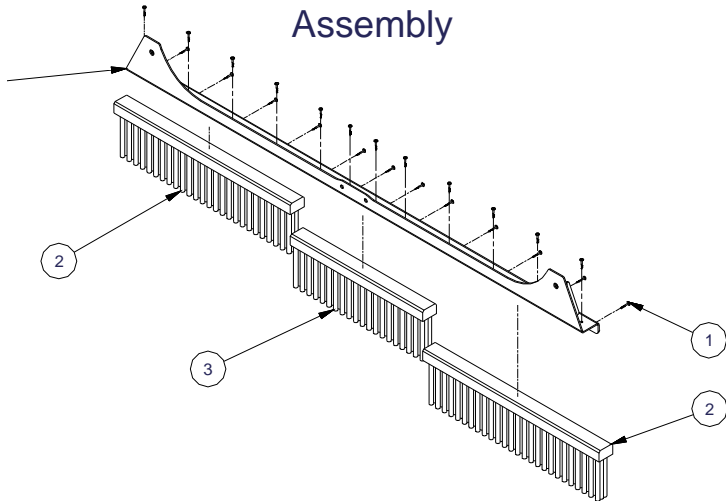

Parts List			
ITEM	QTY	PART NUMBER	DESCRIPTION
1	24	1261823	Screw
2	2	2010	Brush
3	1	2010__	Center Brush
4	1	D__06A	Broom Weldment

PART NUMBERS and DESCRIPTION

Pulverizer Roll Assembly

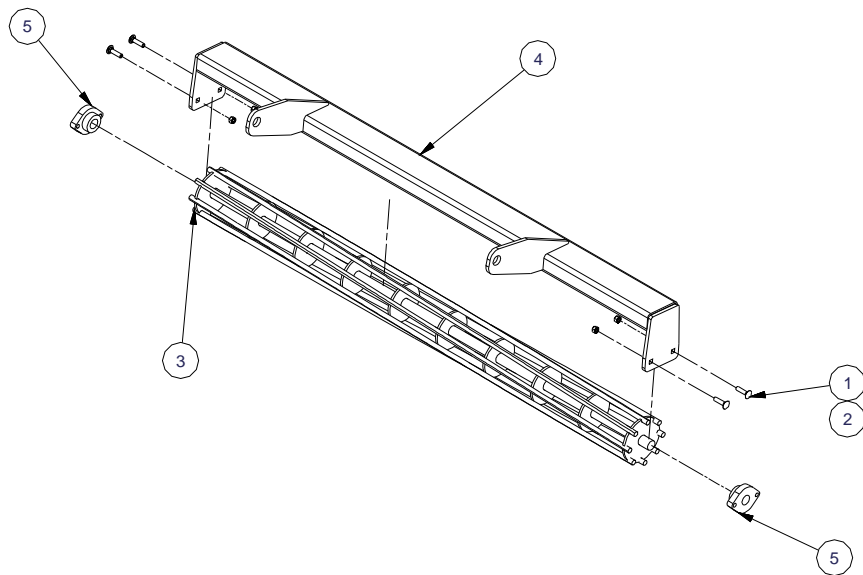

Parts List			
ITEM	QTY	PART NUMBER	DESCRIPTION
1	4	38112C	Carriage Bolt
2	4	38N	Hex Nut
3	1	D_ _ 04A	Roller
4	1	D_ _ 04B	Roller Frame
5	2	SBFD205 -16	2 Bolt Bearing

WARRANTY



All new Reist machinery is warranted to be free from defects in material or workmanship, which may cause failure under normal usage and service when used for the purpose, intended, for a period of 12 months. This warranty applies only to a new Reist product, there being no warranty of any nature in respect to new products that have been modified or altered, repaired, neglected, or used in any way, which, in the opinion of Reist adversely affects its performance.

In the event of failure of a part or parts, and upon inspection, Reist is satisfied that failure is due to defective material or workmanship within 12 calendar months, from the date of delivery to an end user, such defective part or parts will be repaired or replaced by Reist at his business location. It is the responsibility of the buyer, at his expense, to transport the machine or equipment to the manufacturer service shop or, to an authorized service depot or, alternatively, to reimburse Reist for any travel or transportation expense involved in fulfilling this warranty.

When requested by Reist, part or parts shall be returned for inspection, transportation prepaid, to a place designated by Reist. **IN NO EVENT SHALL THE BUYER BE ENTITLED TO RECOVER FOR INCIDENTAL OR CONSEQUENTIAL DAMAGES, INCLUDING, BUT NOT LIMITED TO, LOSS OF PRODUCT, INCONVENIENCE, RENTAL OR REPLACEMENT EQUIPMENT, LOSS OF PROFIT, OR OTHER COMMERCIAL LOSS.**

This warranty becomes void and null if the equipment is modified, breaks down as the result of an accident, is not operated according to manufacturers recommendations, damaged by negligence or if maintenance has not been carried out as specified.

THIS WARRANTY IS NOT TRANSFERABLE

Proof of Purchase

Date of purchase (yyyy mm dd)		Model		Serial #	
Dealer purchased from		City		State or Province	Country
First Name		Last Name		Phone # (include area code)	
Address				State or Province	Country
City	Postal Code	Reist Industries Inc. 100 Union St. Elmira Ontario N3B 2Z2		519-669-1501	

Proof of Purchase

Date of purchase (yyyy mm dd)		Model		Serial #	
Dealer purchased from		City		State or Province	Country
First Name		Last Name		Phone # (include area code)	
Address				State or Province	Country
City	Postal Code	Reist Industries Inc. 100 Union St. Elmira Ontario N3B 2Z2		519-669-1501	

**Reist Industries (Elmira) Ont.
100 Union St., Elmira
Ontario, Canada, N3B 2Z2
www.reistindustries.com**