

REIST
INDUSTRIES Inc.

Aera Seeder

OPERATOR & PARTS MANUAL

Serial # starting at I2042

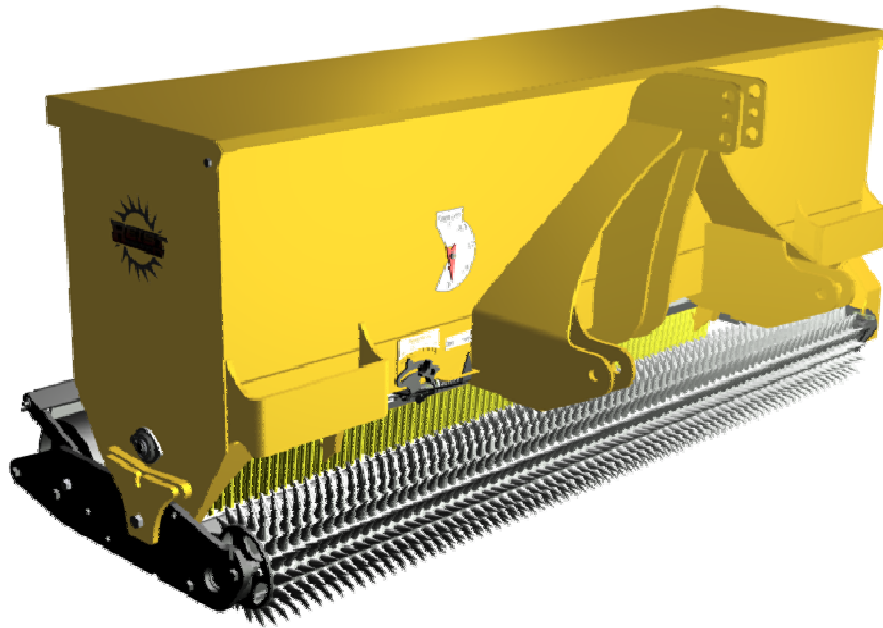

TABLE OF CONTENTS



ITEM	PAGE
INTRODUCTION	2
SAFETY	3
CALIBRATION	4
STANDARD ROLLER ASSEMBLY	5
DOUBLE ROLLER ASSEMBLY	6
KNIFING ROLLER ASSEMBLY	7
STORAGE	8
PARTS	9-17
WARRANTY	18

CONGRATULATIONS!!

Thank you for choosing the **Reist Area Seeder**. We feel confident that this equipment will meet your expectations in workmanship, reliability and performance.

This manual is to assist you with the safe operation of the Area Seeder.

The Reist Area Seeder

Is a versatile piece of equipment to assist you in various primary and over seeding needs.

MODEL NO. _____ **SERIAL NO.** _____.



CAUTION !

1. For proper safe operation we recommend that the tractor be equipped with an approved Roll-Over Protective Structure and Safety Belt.
2. Do not operate an engine in a confined or non-ventilated area.
3. Do not perform any adjustments or repairs with engine running.
4. Always lower 3 PT hitch to ground before performing adjustments or repairs.
5. Do not operate on excessive incline and always be careful when turning on slopes.
6. Never carry passengers on implement or tractor.
7. Never let a child operate machinery.
8. Hydraulic fluid under pressure can cause serious injury. Do Not use your hands to locate leaks.
9. It is the owner's responsibility to make sure that all operators read this manual before operating the equipment.

Calibrating Seed Flow

To calibrate the seed flow rate, you need a weigh scale and small container.

1. Pour seed into seed box. (Each kind of seed needs to be calibrated separately).
2. Insert calibration tray in bottom of seeder on mounts.
3. Set Seed Rate Indicator to an approximate seed rate .
4. With seed flow open, drive the distance of 100 feet. (drive at the same speed as what you are going to drive when seeding).
5. Weigh seed in the calibration tray and multiply by 2. This equals pounds per thousand feet.

Example: 4lb x 2 = 8lb per thousand square ft.

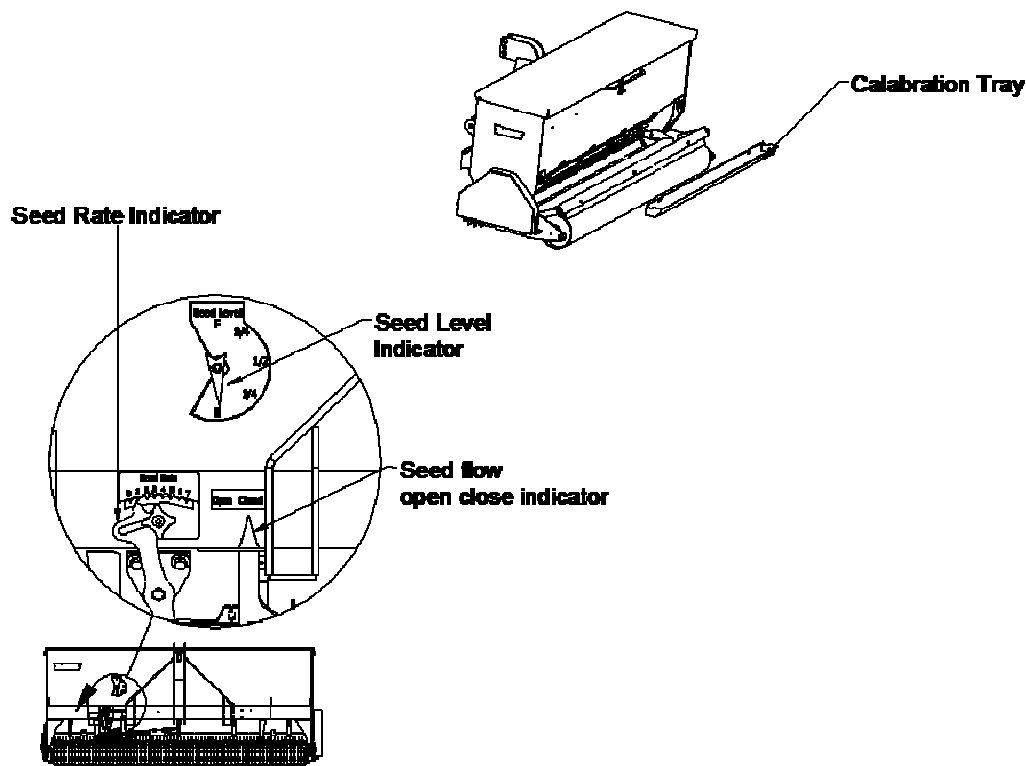

Standard Roller Assembly



Standard

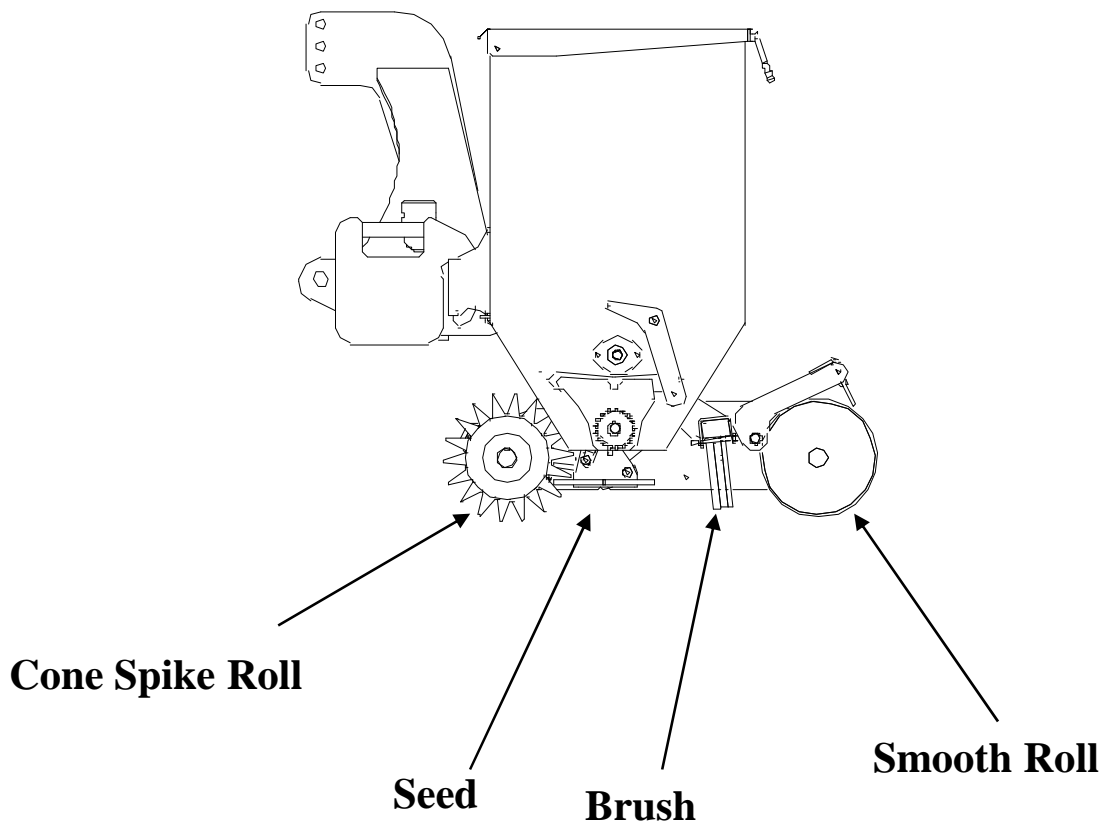

Great for primary and over seeding

For primary seeding, the spike roll breaks up clumps and packs the ground. The seed is then dropped by the seeder and the brush lightly covers the seed. The smooth roll presses the soil to keep the moisture in the ground.

For over seeding the spiked roll pokes small holes into the ground. to moisture, The seed that falls onto the grass is brushed into the holes created by the spike roller. The smooth roll presses down to cover the seed and keep the moisture in.

Double Spike Rolls (Optional)

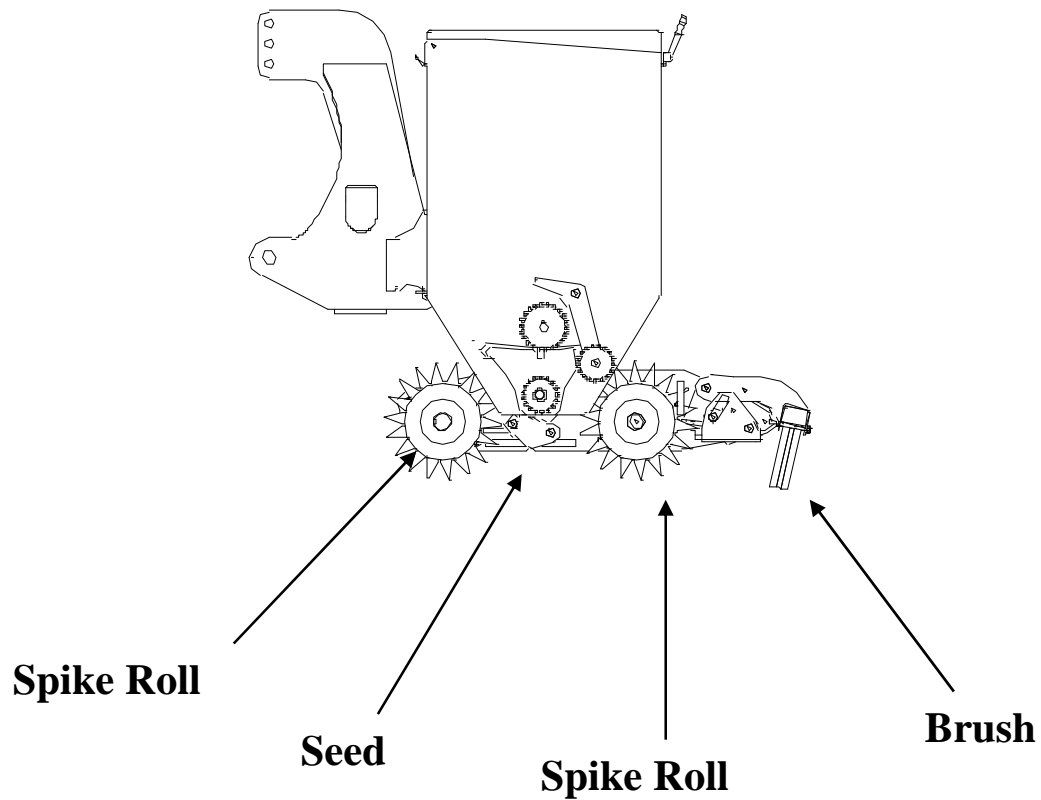

Double the Number of Holes

Over seeding with two spiked rolls has twice the number of holes than the standard roller assembly. Both rolls poke small holes into the ground. Seed that falls onto the grass is brushed into the small holes created by the spike rolls.

Knifing Rolls (Optional)

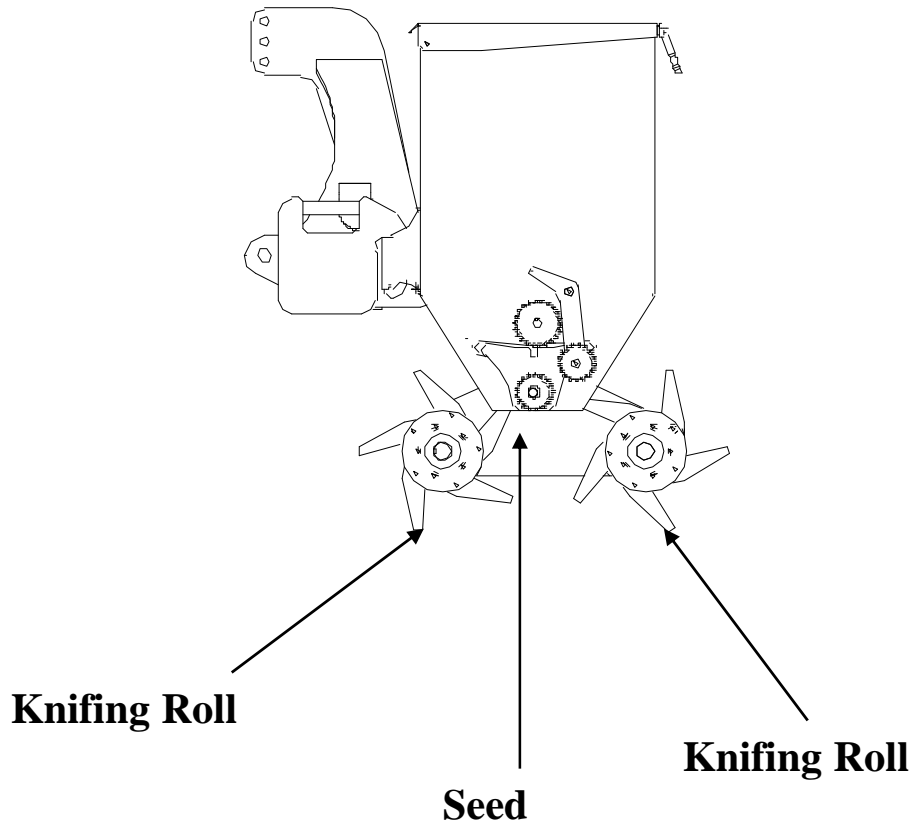

Knifing Rolls

With the Knifing Rolls the knives slice into the ground doing a number of things. It aerates, thatches, loosens and brings up dead grass and other growth between the grass and soil. It slices the roots which causes the grass to grow thicker.

Storage



1. Store in dry ventilated area.
2. Set on either concrete pad, some wood blocks, or plywood.
3. Store with hydraulic cylinder piston rod in retracted position.
4. Clean before putting into storage.
5. Touch-up paint as needed.
6. Oil seeder chain

PARTS

Aera Seeder Frame

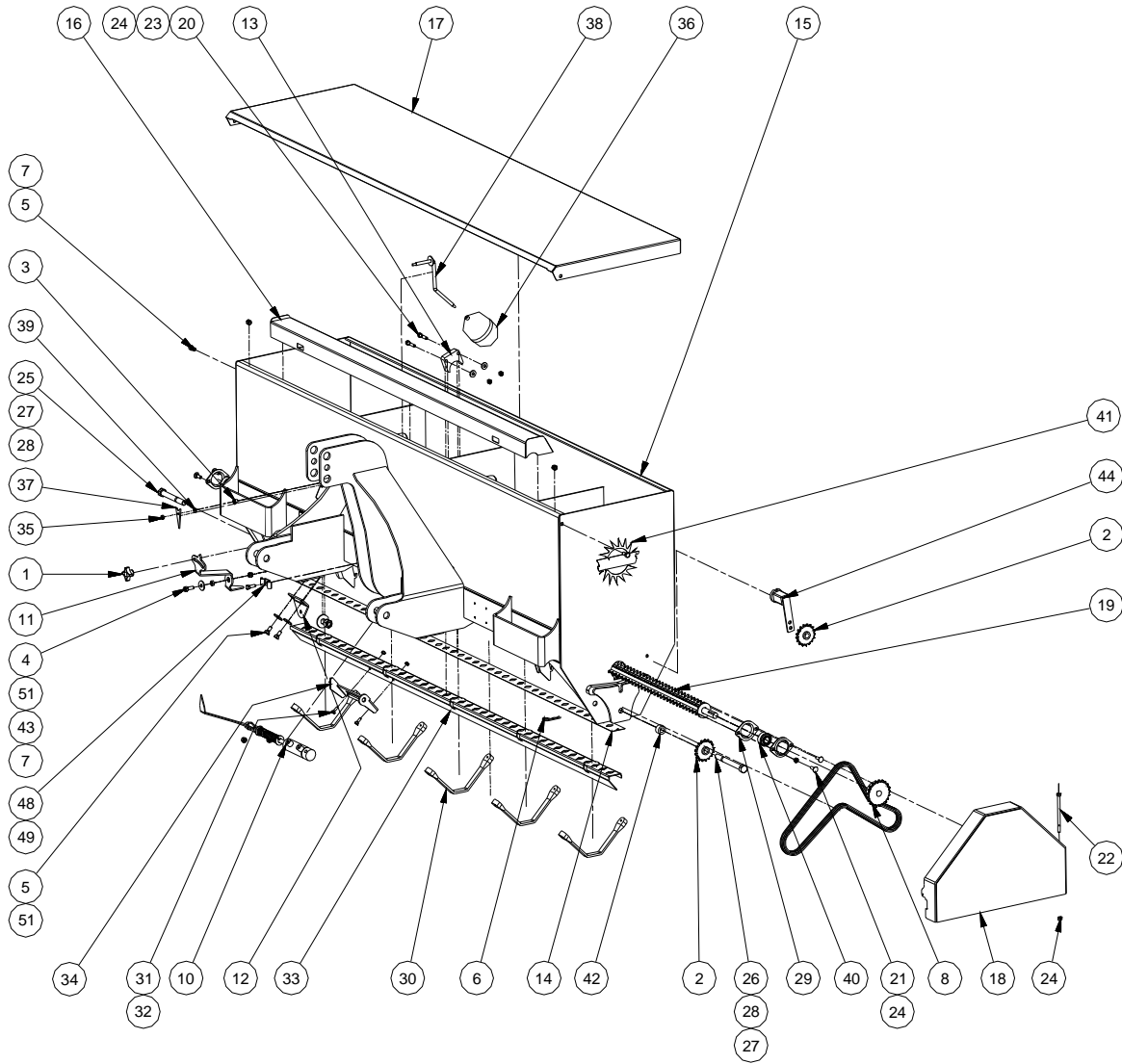

PARTS List



Part numbers with spaces, enter width of Aera Seeder in inches.
 Example: 5027 _ _
 Enter as:502772

Parts List			
ITEM	QTY	PART NUMBER	DESCRIPTION
1	1	134-022	Knob
2	2	20401708	Idler Sprocket
3	2	315-709	Snap Bushing
4	1	38*1	Hex Bolt
5	4	3834	Hex Bolt
6	1	383503	Hair pin
7	4	38CLN	Lock Nut
8	1	40B21-3/4	Sprocket
9	1	40RC	Drive Chain (not shown)
10	1	5027	Cylinder Assembly
11	1	5057	Rate Lever
12	1	5059	Rate Lever bolted Mount
13	1	5060	Center Agitater Brg
14	1	5085 _ _A	Seed Insert
15	1	5087 _ _	Aera Seeder Frame
16	2	5088	Calibration Tray
17	1	5090 _ _	Aera Seeder Lid
18	1	5092	Shield
19	1	5093 _ _	Agitater Shaft
20	2	516112	Hex Bolt
21	4	5161C	Carriage Bolt
22	1	5165	Hex Bolt
23	2	516F	Washer
24	7	516N	Hex Nuts
25	1	585	5/8x5 NC Bolt
26	1	586	5/8x6 NC bolt
27	2	58F	5/8 Flat Washer
28	2	58N	58 NC Nut
29	4	MST47	Brg Flange
30	5	SH-9	Tarp Strap
31	2	1434	Hex Bolt
32	2	14N	Hex Nut
33	1	5086 _ _A	SS Seed Slide
34	1	5094	Cyl Mount
35	1	14N	Hex Nut
36	1	3305471	Seed Level Ball
37	1	5095	Seed Level Arrow
38	1	5096	Seed Level Rod
39	1	14FW	Washer A
40	2	UC204012	Bearing Insert
41	2	Reist Decal Spiked	
42	2	5025	Bushing
43	1	5137	Rate Lever Spacer
44	1	SE 15-02	
45	1		Roller Chain
46	1	38*2	Hex Bolt
47	1	38FW	Washer
48	1	C-1037 Hose Clip	Hose Clip
49	1	5161	Hex Bolt
50	4	12FSLN	Flange Nut
51	3	38F	Plain Washer

PARTS Cylinder

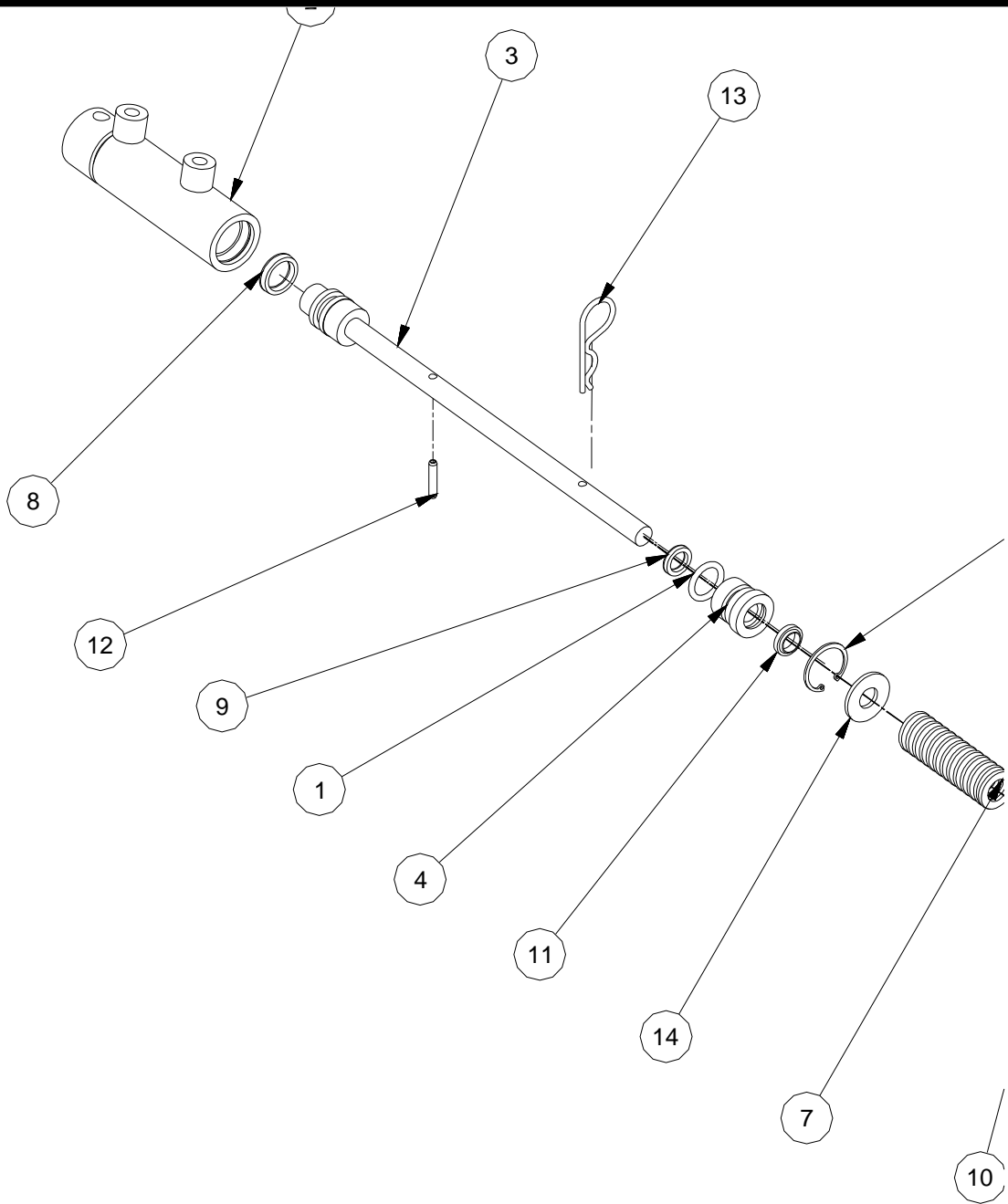

Part numbers with spaces, enter width of Aera Seeder in inches.
Example: 5027__
Enter as:502772

PARTS

Standard Roll Assembly

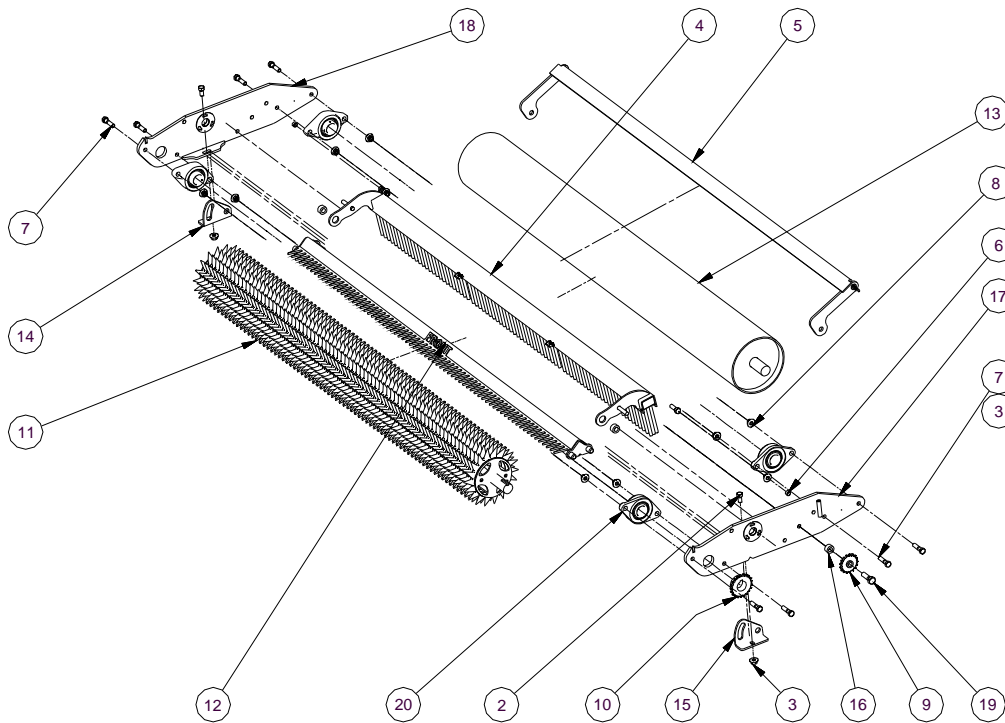

Part numbers with spaces, enter width of Aera Seeder in inches.
 Example: 5027__
 Enter as:502772

Parts List				Parts List			
ITEM	QTY	PART NUMBER	DESCRIPTION	ITEM	QTY	PART NUMBER	DESCRIPTION
1	1	40RC	Roller Chain	11	1	5014__	Spike Drive Roll
2	2	12*1	Hex Bolt	12	1	5015__	Front Peg Scraper
3	4	12FSLN	Flange Nut	13	1	5016__	Smooth Roll
4	1	5026__	Aera Seeder Brush	14	1	5019	Peg Scraper Hinge Right
5	1	5027__	Smooth Roll Scraper	15	1	5020	Peg Scraper Hinge Left
6	2	MSI-0810-06	Scraper Bushing	16	1	5025	Idler Spacer
7	8	12*2	1/2x2 NC Bolt	17	1	5101	Side Plate Left S
8	8	12FSLN	Flange Nut	18	1	5102	Side Plate Right S
9	1	20401708	Idler Sprocket	19	1	58*2	5/8x2 NC bolt
10	1	40B21-1-1/2	Drive Sprocket	20	4	UCLF208108TC	Bearing

PARTS Spiked Drive Roll



Spiked Drive Roll

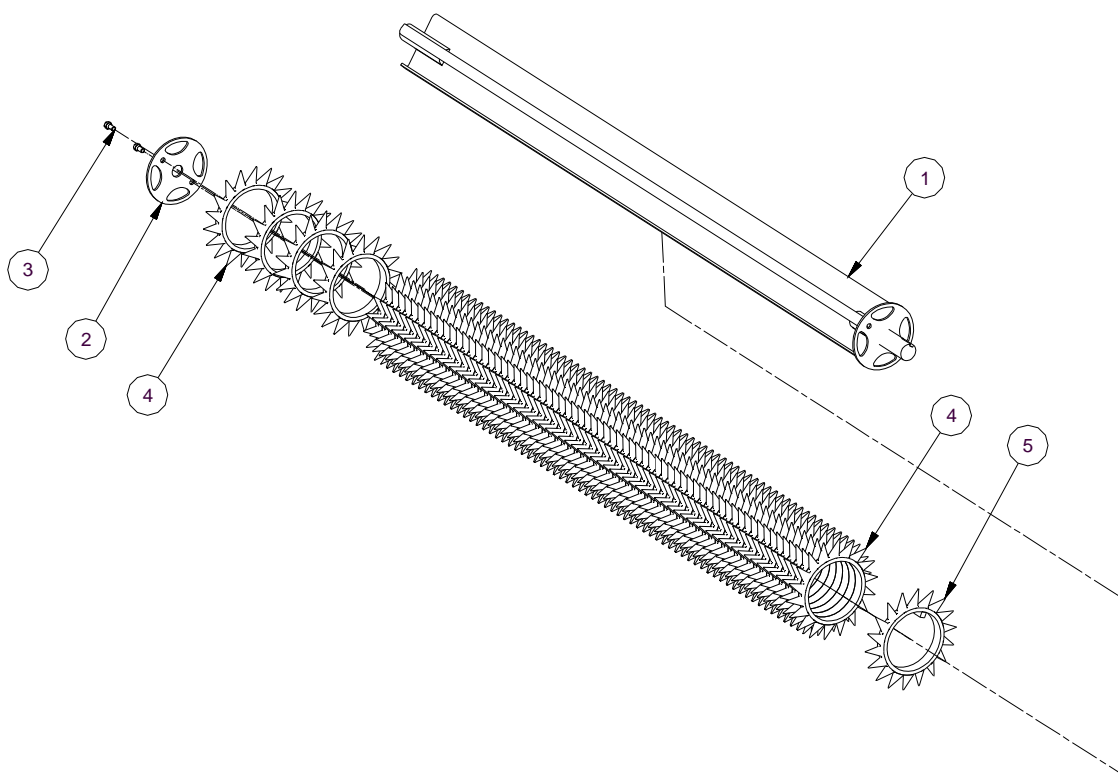

Part numbers with spaces, enter width of Aera Seeder in inches.
 Example: 5027__
 Enter as:502772

Parts List			
ITEM	QTY	PART NUMBER	DESCRIPTION
3	2	3834	Bolt
1	1	5064	Over Seeder Drive Roll
2	1	5049	Spike Washer
4	71	5066	Over Seeder Spike machined slanted
5	1	5067	Over Seeder Drive Spike Slanted

PARTS Broom & Scraper

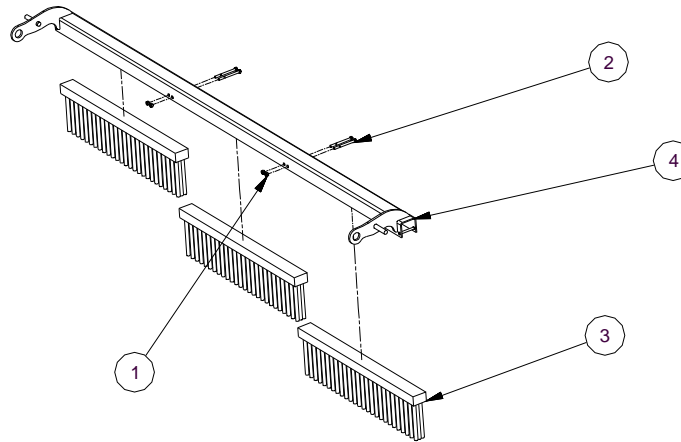

Part numbers with spaces, enter width of Aera Seeder in inches.
 Example: 5027__
 Enter as:502772

Parts List			
ITEM	QTY	PART NUMBER	DESCRIPTION
1	4	14N	Hex Nut
2	4	14*3	1/4x3 bolt
3	3	2010	Main Frame Brush
4	1	5039__	Aera Seeder Broom Mount

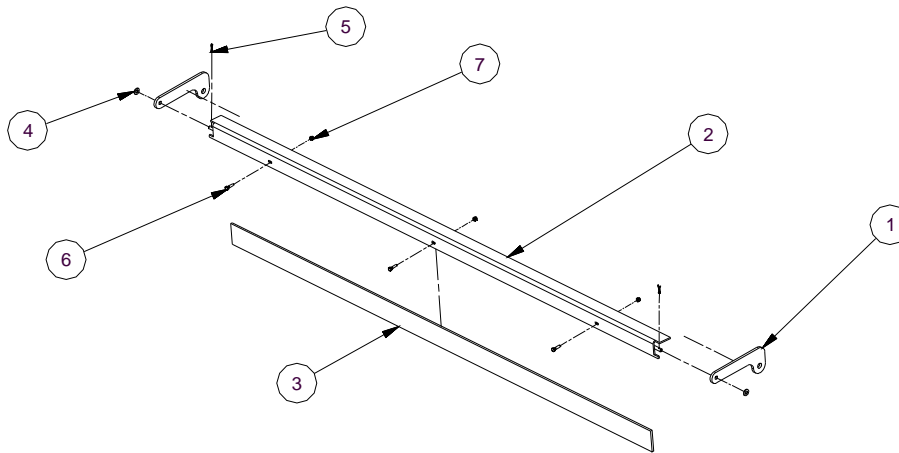

Part numbers with spaces, enter width of Aera Seeder in inches.
 Example: 5027__
 Enter as:502772

Parts List			
ITEM	QTY	PART NUMBER	DESCRIPTION
3	1	1/4x3x__UHMW	UHMW Scraper
6	3	14*1	1/4x1 NC Nut
7	3	14CLN	1/4 Lock Nut
5	2	1834CP	Cotter Pin
4	2	38F	3/8 Flat Washer
2	1	5040__	Smooth Roll Scraper Angle
1	2	5041	Scraper Bracket

PARTS Knifing Assembly

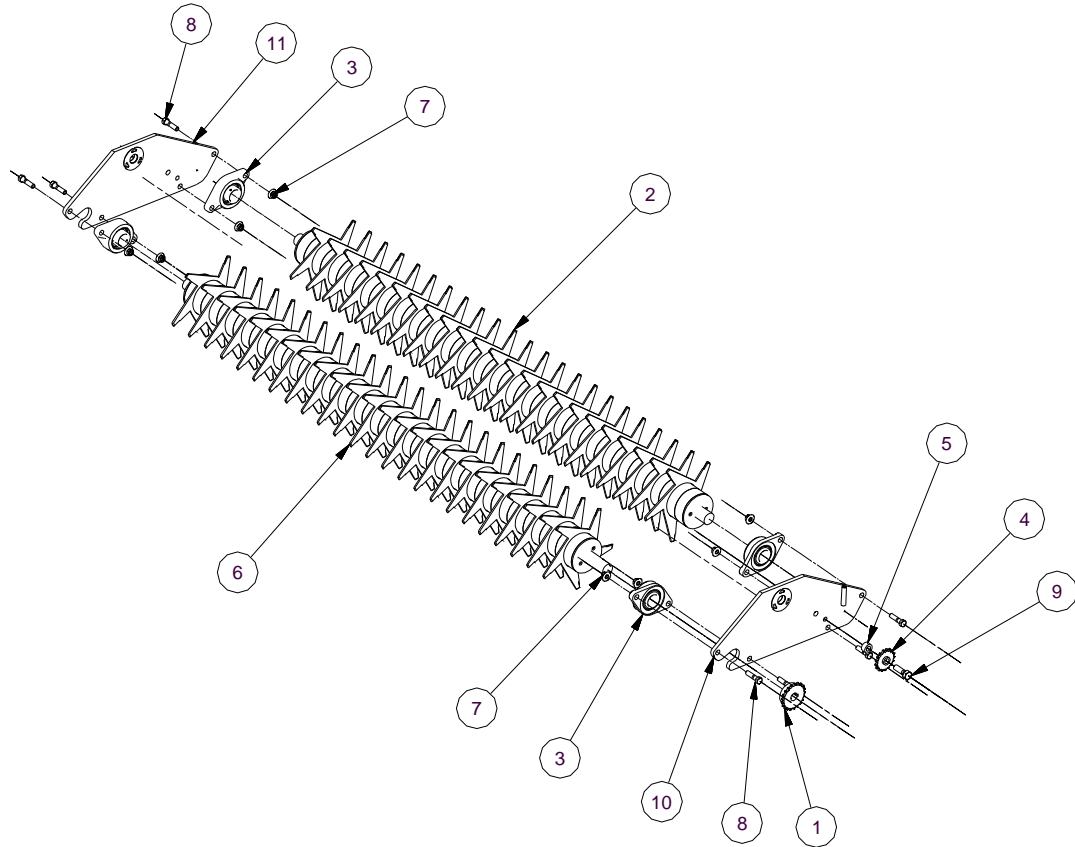

Part numbers with spaces, enter width of Aera Seeder in inches.
 Example: 5027__
 Enter as:502772

Parts List			
ITEM	QTY	PART NUMBER	DESCRIPTION
1	1	40B21-1-1/2	Drive Sprocket
2	1		Slitter Idler Roll Assembly
3	4	UCLF208108TC	Bearing
4	1	4W20401708	Idler Sprocket
5	1	5025	Idler Spacer
6	1		Slitter Drive Roll Assembly
7	8	12FSLN	Flange Nut
8	8	12*2	Hex Bolt
9	1	58*2	Hex Bolt
10	1		Slitter Side Plate L
11	1		Slitter Side Plate R

PARTS Double Spike Roll

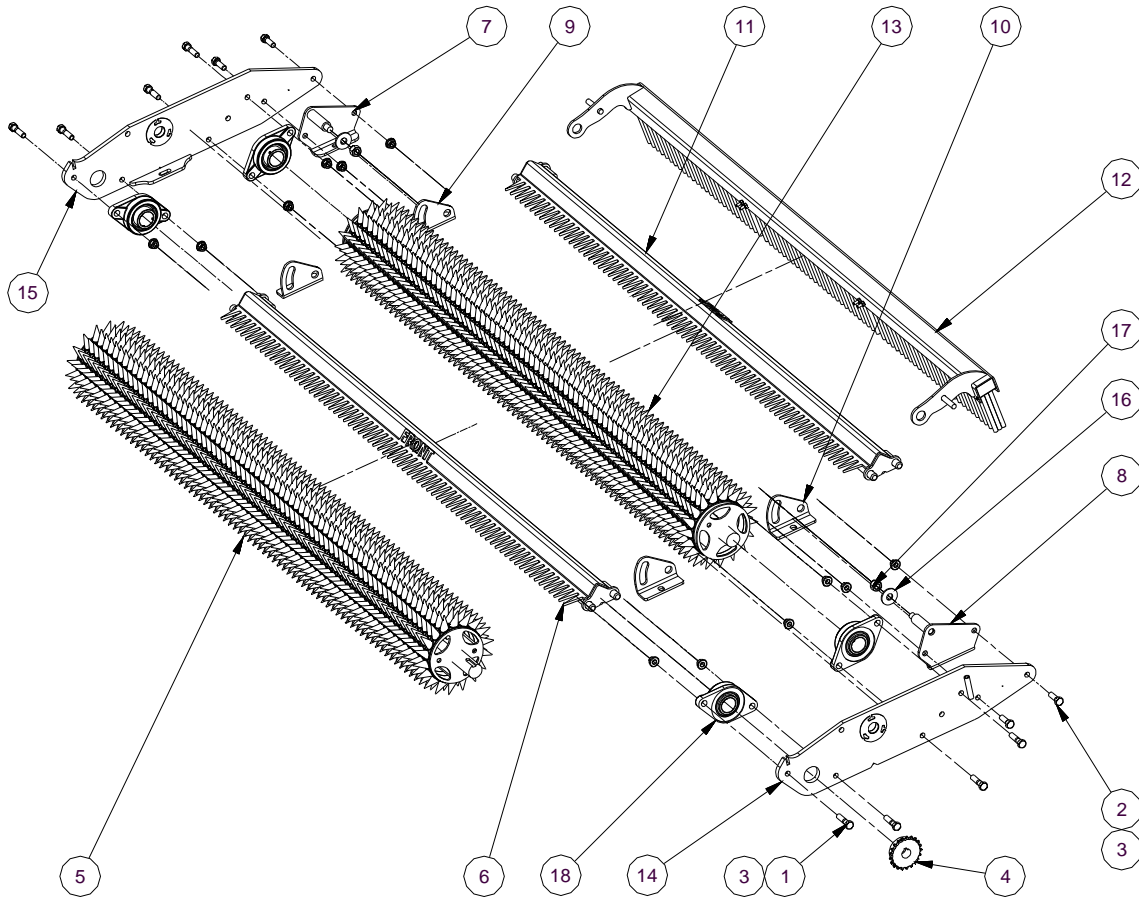

Part numbers with spaces, enter width of Aera Seeder in inches.
 Example: 5027_ _
 Enter as:502772

Parts List			
ITEM	QTY	PART NUMBER	DESCRIPTION
1	8	12*2	1/2x2 NC Bolt
2	4	12112	Bolt
3	12	12FLSN	Flange Nut
4	1	40B21-1-1/2	Drive Sprocket
5	1	5014_ _	Spike Drive Roll
6	1	5015_ _	Front Peg Scraper
7	1	5017	Rear Broom Bracket Right
8	1	5018	Rear Broom Bracket Left
9	2	5019	Peg Scraper Hinge Right
10	2	5020	Peg Scraper Hinge Left
11	1	5021_ _	Peg Scraper Rear
12	1	5026_ _	Aera Seeder Brush
13	1	5063_ _	Spike Drive Roll
14	1	5101	Side Plate Left S
15	1	5102	Side Plate Right S
16	2	58F	5/8 Flat Washer
17	2	58N	58 NC Nut
18	4	UCLF208108TC	Bearing

PARTS Double Spike Roll 2nd Position

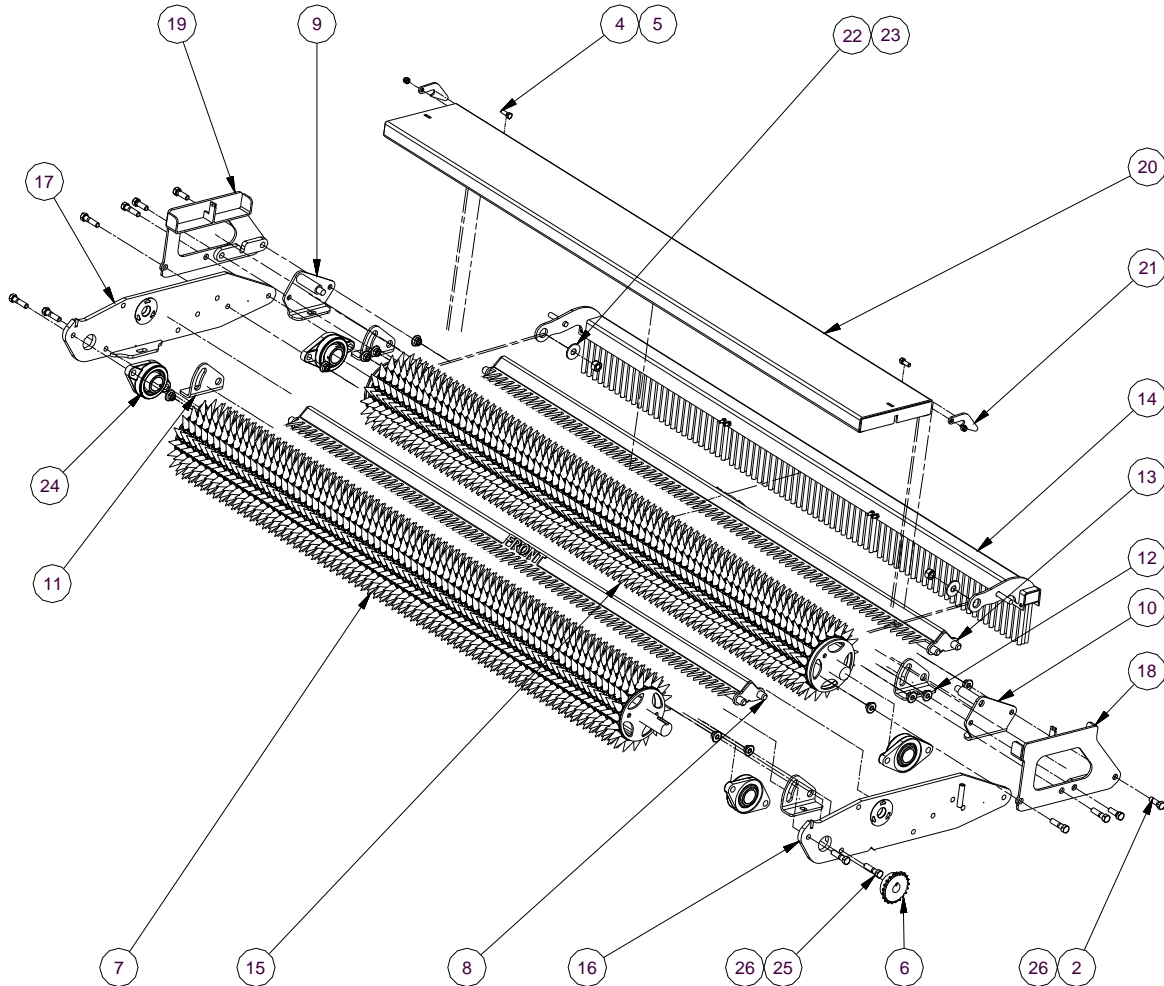

Parts List				Parts List			
ITEM	QTY	PART NUMBER	DESCRIPTION	ITEM	QTY	PART NUMBER	DESCRIPTION
2	4	12112	Bolt	15	1	5063_ _	Spike Drive Roll
4	2	381	Bolt	16	1	5101	Side Plate Left S
5	2	38CLN	Lock Nut	17	1	5102	Side Plate Right S
6	1	40B21-1-1/2	Drive Sprocket	18	1	5105	Roll shield Mount Left
7	1	5014_ _	Spike Drive Roll	19	1	5106	Roller Shield Mount Right
8	1	5015_ _	Front Peg Scraper	20	1	5107_ _	Roll Shield
9	1	5017	Rear Broom Bracket Right	21	2	5108	Broom Hook
10	1	5018	Rear Broom Bracket Left	22	2	58F	5/8 Flat Washer
11	2	5019	Peg Scraper Hinge Right	23	2	58N	58 NC Nut
12	2	5020	Peg Scraper Hinge Left	24	4	UCLF208108TC	Bearing
13	1	5021_ _	Peg Scraper Rear	25	8	12*2	Hex Bolt
14	1	5026_ _	Aera Seeder Brush	26	12	12FSLN	Flange Nut

WARRANTY



All new Reist machinery is warranted to be free from defects in material or workmanship, which may cause failure under normal usage and service when used for the purpose, intended, for a period of 12 months. This warranty applies only to a new Reist product, there being no warranty of any nature in respect to new products that have been modified or altered, repaired, neglected, or used in any way, which, in the opinion of Reist adversely affects its performance.

In the event of failure of a part or parts, and upon inspection, Reist is satisfied that failure is due to defective material or workmanship within 12 calendar months, from the date of delivery to an end user, such defective part or parts will be repaired or replaced by Reist at his business location. It is the responsibility of the buyer, at his expense, to transport the machine or equipment to the manufacturer service shop or, to an authorized service depot or, alternatively, to reimburse Reist for any travel or transportation expense involved in fulfilling this warranty.

When requested by Reist, part or parts shall be returned for inspection, transportation prepaid, to a place designated by Reist. **IN NO EVENT SHALL THE BUYER BE ENTITLED TO RECOVER FOR INCIDENTAL OR CONSEQUENTIAL DAMAGES, INCLUDING, BUT NOT LIMITED TO, LOSS OF PRODUCT, INCONVENIENCE, RENTAL OR REPLACEMENT EQUIPMENT, LOSS OF PROFIT, OR OTHER COMMERCIAL LOSS.**

This warranty becomes void and null if the equipment is modified, breaks down as the result of an accident, is not operated according to manufacturers recommendations, damaged by negligence or if maintenance has not been carried out as specified.

THIS WARRANTY IS NOT TRANSFERABLE

Proof of Purchase

Date of purchase (yyyy mm dd)		Model		Serial #	
Dealer purchased from		City		State or Province	Country
First Name		Last Name		Phone # (include area code)	
Address				State or Province	Country
City	Postal Code	Reist Industries Inc. 100 Union St. Elmira Ontario N3B 2Z2		519-669-1501	

Proof of Purchase

Date of purchase (yyyy mm dd)		Model		Serial #	
Dealer purchased from		City		State or Province	Country
First Name		Last Name		Phone # (include area code)	
Address				State or Province	Country
City	Postal Code	Reist Industries Inc. 100 Union St. Elmira Ontario N3B 2Z2		519-669-1501	

**Reist Industries (Elmira) Ont.
100 Union St., Elmira
Ontario, Canada, N3B 2Z2
www.reistindustries.com**