

**INNOVATION WORKING FOR YOU**

**S100 and S200  
Broadcast Spreader  
Operator's and Parts Manual**

REIST Industries Inc.  
100 Union Street  
Elmira, Ontario, Canada  
N3B 2Z2

Phone: 519-669-1501  
Fax: 519-669-3021  
Toll Free: 1-877-467-3478  
[www.reistindustries.com](http://www.reistindustries.com)

Revised: February, 2011  
Effective Serial Number: S100 is D10124 and up  
S200 is D10134 and up

## Contents

INTRODUCTION.....	3
PRODUCT CONFIGURATION .....	4
GENERAL SAFETY PRECAUTIONS .....	5
OPERATION AND TRANSPORTATION ON PUBLIC ROADS AND AREAS.....	7
MOUNTING.....	7
SETUP INSTRUCTIONS .....	8
LOADING HOPPER WITH PRODUCT .....	9
FILLING HOPPER.....	9
SELF-LOADING FEATURE .....	9
USING THE BROADCAST SPREADER.....	10
OPERATION.....	10
SIDEWALK DEFLECTOR / TARP COVER.....	11
MAINTENANCE .....	12
STORAGE.....	12
PARTS .....	13
S100 Drive Mechanism Parts Drawing.....	13
S100 Spreader Plumbing Parts Drawing.....	15
S100 Spreader Flow Control Parts Drawing .....	16
S100 Hydraulic Unloading Hitch Parts Drawing .....	17
S200 Spreader Drive Mechanism Parts Drawing .....	18
S200 Spreader Drive Hydraulic Plumbing Parts Drawing .....	20
WARRANTY INFORMATION.....	21

**Unless otherwise noted, the instructions and information contained within this Operator's and Parts Manual pertain to both the S100 and S200 Broadcast Spreaders manufactured by REIST Industries Inc.**

Record your product information for future reference:

Model Number: \_\_\_\_\_

Serial Number: \_\_\_\_\_

In Service Date: \_\_\_\_\_

Sold By: \_\_\_\_\_

# INTRODUCTION

Thank you for choosing a REIST Broadcast Spreader.

We feel confident that this equipment will meet your expectations in workmanship, reliability and performance when used as designed. This manual is to assist you with the safe operation of the REIST S100 and S200 Broadcast Spreaders. It also has a parts list to help you when replacement parts are required. Any person who will be assembling, attaching, operating, maintaining, or operating this product and the prime mover to which it is attached, are required to read and completely understand the information and instructions contained in this manual and that of the prime mover. Always obtain further assistance by contacting the dealer from which this product was purchased or by contacting REIST Industries at the telephone number or address below. Keep this manual available for reference whenever this product is being handled or used and we recommend that it is reviewed periodically and before seasonal use. Provide this manual to any new owners and/or operators and ensure they fully understand the safe operation of this equipment before it is placed in service.

Replacement copies of this manual are available for downloading at:  
[www.reistindustries.com](http://www.reistindustries.com)

Innovation Working For You

## **REIST Industries Inc.**

100 Union Street  
Elmira, Ontario, Canada  
N3B 2Z2

Phone: 519-669-1501  
Fax: 519-669-3021  
Toll Free: 1-877-467-3478

## **REIST Industries USA Inc.**

844 E. Greenwood Street  
Abbeville, South Carolina  
USA 29620

Phone: 1-864-366-0172  
Toll Free: 1-888-369-1444

The illustrations and information contained within this manual were current at the time of publication. Under our policy of continuous improvement, we reserve the right to change specifications and designs without prior notice. The illustrations do not necessarily show the standard version of product offered by REIST Industries.

## PRODUCT CONFIGURATION

REIST Industries manufactures two models of durable all-season broadcast spreaders ideal for grass seed, screened top soil, fertilizer, sand & salt in ½ yd. and 1½ yd. hopper capacities. Depending upon the model and the material, the casting range is 3 ft. to 60 ft., (1 m to 18 m) and both models have spinner speed controls allowing the operator to control distribution for maximum effectiveness. The application rates are controlled through a manual flow rate adjustment slider or an optional hydraulic shut-off gate, while the standard in-hopper agitator ensures even material flow to the spinner. The galvanized ½ yd S100 model spreader has an optionally available 36" (91,4 cm) wide drop shield to focus distribution to where it is needed most, expanding the seasonal use and making it ideal for winter sidewalk maintenance. The large capacity, 1½ yd S200 model spreader has twin hydraulic spinners and agitators for expanded coverage in parking lots allowing the operator to finish the job quicker.

When mounted to a loader, an innovative design feature common to both the REIST S100 and S200 Spreaders is that both models can self-load, saving time and money. To match to existing equipment, both spreaders are available with a 3 Point Hitch and can also be equipped with the optional hydraulic self-load feature. The S100 can be fitted with an optional tow behind dolly, ideal when used together with a front mounted snow clearing attachment.

	<b>Model S100</b>	<b>Model S200</b>
	<ul style="list-style-type: none"> <li>• Galvanized</li> <li>• Single spinner</li> </ul>	<ul style="list-style-type: none"> <li>• Twin Rotor</li> <li>• Twin spinners</li> </ul>
<b>Capacity</b>	<b>1/2 yard .46 m</b>	<b>1-1/2 yard</b>
<b>Weight (empty)</b>	<b>370 lb / 170 kg</b>	<b>1300 lb / 590 kgs</b>
<b>Dimensions:</b> (approximant)	<b>48" w x 36" d x 44" h</b> 122 cm x 91 cm x 112 cm	<b>86" w x 42" d x 60" h</b> 218 cm x 107 cm x 152 cm
<b>Hydraulic Requirements</b>	<b>Minimum to Maximum</b> <b>5 gpm to 20 gpm</b> <b>(19 l/m to 76 l/m)</b>  <b>1500 psi to 2500 psi</b> <b>(103 Bar to 172 Bar)</b>	<b>Minimum to Maximum</b> <b>12 gpm to 30 gpm</b> <b>(45 l/m to 114 l/m)</b>  <b>1500 psi to 2500 psi</b> <b>(103 Bar to 172 Bar)</b>



### **WARNING!**

Exceeding the recommended specifications can result in damage to the equipment and will void all REIST Industries' warranties.

The following references are used throughout this Operator's and Parts Manual:

Front or Rear Mounted	Orientation that is determined in relation to the operator of the equipment when seated in the normal operating position of the prime mover
Prime Mover	The engine-driven machine to which this product is attached
Right, Left, Front, Rear	Orientation that is determined in relation to the operator of the equipment when seated in the normal operating position. Unless otherwise noted
Attachment, Implement	Refers to the Broadcast Spreader whether attached or separate from the prime mover
Equipment	Refers to the Implement and / or prime mover whether separate or connected
<b>WARNING, CAUTION, IMPORTANT</b>	A notice that relates to the safe and efficient operation of the Broadcast Spreader or prime mover. Read and understand the reference before attaching or operating the Broadcast Spreader or the prime mover

## GENERAL SAFETY PRECAUTIONS

Careful operation is the best assurance against accidents. It is the owner's responsibility to make sure that all operators read and understand this manual and follow the recommendations, cautions and warnings before connecting to a prime mover and operating the equipment.

Familiarize yourself with all controls and know how to quickly stop the equipment and all rotating parts in the case of an emergency.

Depending upon the model of spreader and the material used, the casting range is 3 ft. to 60 ft., (1 m to 18 m) from the spreader. Know the limitations or restrictions that govern the spreading radius may be dictated by either the material to be dispersed and / or the surroundings. Keep a minimum of 75 ft (23 m) away from bystanders while dispensing product.

Never let an untrained person or a child operate equipment.



### **WARNING!**

#### **DO NOT MODIFY THE BROADCAST SPREADER OR PRIME MOVER**

Modifications may weaken the integrity of the Broadcast Spreader and may impair the operation, safety, and performance of the product. When making repairs, only qualified technicians using the manufacturer's genuine parts, following authorized instructions shall attempt the repair. Never modify any ROPS (Roll Over Protection Structure) or FOPS (Falling Object Protective Structure) equipment or other safety device or remove guarding. Any modifications must be sanctioned in writing by an authorized representative of the manufacturer.



## **WARNING!**

### **STAY CLEAR OF ROTATING OBJECTS**

Keep hands, feet and clothing away from power driven rotating parts.



Never use your hands to clear a clogged agitator. Never allow anyone to reach into the hopper, force objects (i.e. bars, poles, etc.) into the agitator or spinner, or otherwise come in contact with an agitator or spinner or with a non-rotating agitator or spinner. Rotating parts can crush and/or dismember. Keep everyone clear of the spreader until the prime mover engine is off and the hydraulic pressure has been relieved.



## **WARNING!**

### **MAINTAIN AND REPAIR EQUIPMENT SAFELY**

- Do not wear loose clothing, or any accessories that can catch in moving parts
- If you have long hair, cover or secure it so that it does not become entangled in the equipment
- Work on a level surface in a well-lit area.
- Always lower raised equipment to the ground or securely support it to prevent unintentional movement
- Remove and retain the prime mover's ignition key
- Use the correct tool for the job at hand. Make sure they are in good condition for the task required
- Wear the protective equipment specified by the tool manufacturer
- Use care when working on hydraulic systems and understand how to check for and release trapped hydraulic pressure

### **WELDING GALVANIZED MATERIAL**

- Only qualified welders should attempt a weld repair on a galvanized component
- Always ensure proper ventilation, avoid direct contact with zinc oxide smoke, and proper pre-welding preparation work is required

## OPERATION AND TRANSPORTATION ON PUBLIC ROADS AND AREAS

Always adhere to the local laws and regulations concerning traveling or operating on public roadways and areas. Clean all lights, reflectors and mirrors ensuring that all lighting is in working order before moving. Know the area that the discharged material is to be placed is free from hazards and that the discharged material will not create a hazard for vehicular traffic or pedestrians. Always be alert while transporting or operating the equipment. Select a safe ground speed when transporting from one area to another. When traveling on roadways, transport in such a way that faster moving vehicles may pass you safely.

Do not fill the hopper (especially with fertilizer) and transport over long distances, as it may result in packing, causing poor or erratic discharge.

## MOUNTING

Two different methods of mounting are available. A universal Skid Steer mount or a Category 1, three point hitch mount for a tractor. They fasten to the spreader by means of four bolts to allow you to move the spreader between different types of prime movers.

Skid Steer Mount

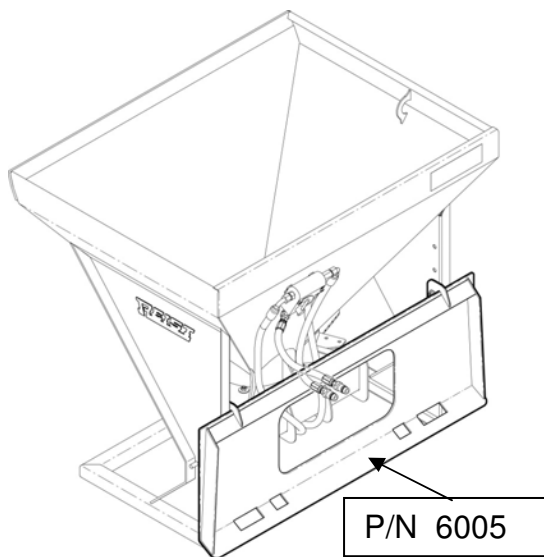

Cat 1, 3 PH Mount

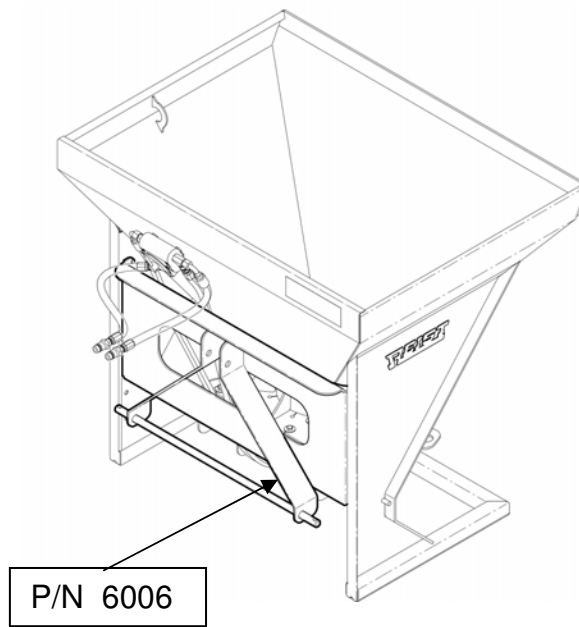

## SETUP INSTRUCTIONS

Improper installation, operation, or maintenance of this equipment could result in serious injury or death. FOLLOW ALL SAFETY INSTRUCTIONS IN THIS MANUAL AND THE PRIME MOVER'S MANUAL(S)

- Refer to the Operator's Manual(s) for your prime mover and follow the mounting instructions contained therein
- Connect the hydraulic lines to the prime mover's hydraulic system
- Ensure that the hose ends and fittings are free of dirt and contamination
- Once attached, and it is safe to do so, carefully raise the Broadcast Spreader and cycle either the loader arms or the 3 Point Hitch to check clearances and to verify that all mounting procedures have been successfully completed
- Refer to the prime mover starting and operating instructions
- Only engage the prime mover's hydraulic system when it is safe to do so
- Verify that the spinner direction is in a clockwise direction when viewed from above the spreader regardless if mounted to the front or rear of the prime mover
  - If the spinner turns in the wrong direction, the hydraulic connections need to be reversed by a qualified technician

## LOADING HOPPER WITH PRODUCT



### **WARNING!**

#### SPREADER MAY TIP WHEN LOADING

Load hopper with product only after the spreader has been properly attached to a prime mover capable of handling a fully loaded broadcast spreader.

- Always read and comply with all safe handling and application instructions and precautions of the product being used as found on the package label
- Always wear protective clothing including safety glasses and a properly fitted breathing mask when filling the hopper to prevent injury to the body and/or inhalation of product. Refer to product manufacturers' labels for specific protective requirements.

### ***FILLING HOPPER***

1. Stop the prime mover and spreader on a hard, level surface
2. Engage park brake, lower the spreader to the ground
3. Shut engine off and remove and retain the ignition key,
4. Release residual hydraulic pressure before dismounting from prime mover
5. Check agitator to make sure it functions properly.
6. Check spinner vanes for wear.
7. Check flow control gates to make sure they open and close properly.
8. Fully close flow control gates
9. Carefully fill hopper with product ensuring that the product is free flowing and does not contain stones or hard lumps
10. Do not over fill or carry bags of additional product on top of the spreader

### ***SELF-LOADING FEATURE***

When mounted to the loader arms of a prime mover that are capable of rolling the spreader forward, the hopper of the REIST Industries' spreader can be filled by carefully driving into a pile of product - such as sand or de-icing salt using an action similar to that of a front end loader.

- Always ease into a pile, never hit a pile at a high rate of speed, damage to the equipment or personal injury may result
- Always make sure the pile consists of loose material and is not frozen or compacted
- Using the prime mover's tilt function, slowly raise the spreader as you move into the pile to aid filling

## USING THE BROADCAST SPREADER



### **WARNING!**

READ OPERATOR'S MANUAL BEFORE OPERATING

Do not operate equipment until you are completely trained by a qualified operator in how to use the controls, understand the machine's capabilities, dimensions, and all safety requirements. Refer to your equipment's manual for these instructions.

### ***OPERATION***

Product distribution rate is governed by several factors:

- Material or product being spread
- The travel speed of the prime mover
- The spinner speed (has the greatest impact upon area covered per pass and is operator controlled)
- The product / flow regulator opening size (manually set by the operator)

Consult the product packaging or information sheet if available, to determine the recommended amount of coverage and adjust the spreader or your travel speed accordingly.

If spreading material over a large area, have a plan to avoid missed areas or high concentrations. To ensure full coverage, set spreader to disperse product at half the required rate and go over the area twice with the 2<sup>nd</sup> pass perpendicular to the first.

### **IMPORTANT**

Once you have moved to the location you wish to start product distribution with the Broadcast Spreader, be sure the area is clear of all bystanders and other hazards.

- Do not operate an engine in confined or non-ventilated area
- Do not perform adjustments or repairs with the engine running
- Always lower raised equipment to the ground or securely support it to prevent unintentional movement
- Do not operate on excessive inclines or side slopes – know the limitations of the prime mover – be careful when turning on slopes as a rollover condition may exist
- Never carry passengers
- Keep bystanders away from the machine when in operation
- Know how to quickly stop the equipment and all rotating parts in the case of an emergency. Refer to the prime mover's Operator's Manual
- Stop the prime mover, lower implements and turn off the engine before dismounting

## ***SIDEWALK DEFLECTOR / TARP COVER***

The galvanized ½ yd S100 model spreader has an optionally available 36" (91,4 cm) wide sidewalk deflector to focus distribution to where it is needed most, expanding the seasonal use and making it ideal for winter sidewalk maintenance. The sidewalk deflector can easily be removed and installed. Simply hook the mounting slot of the deflector onto the mounting peg on the spreader and swing the latch to lock the deflector in place. When using the deflector, use a slow spinner speed. Adjust the flow control to the spinner to achieve the desired application rate.

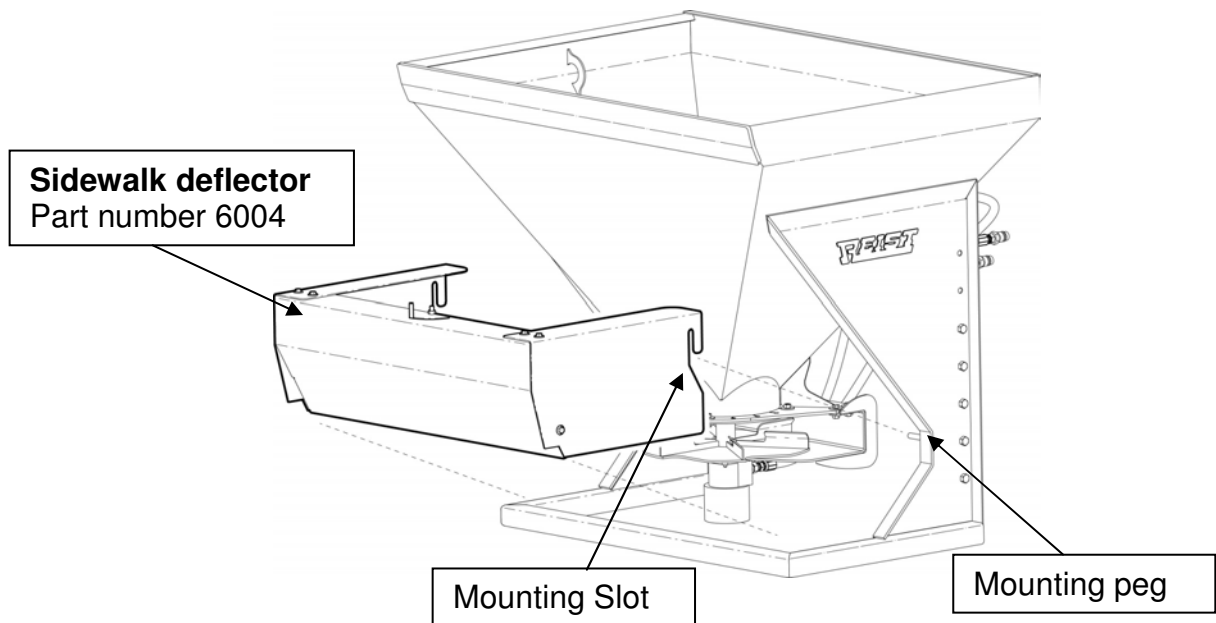

The optional tarp cover is easily slipped over the hopper and held securely with a drawstring.

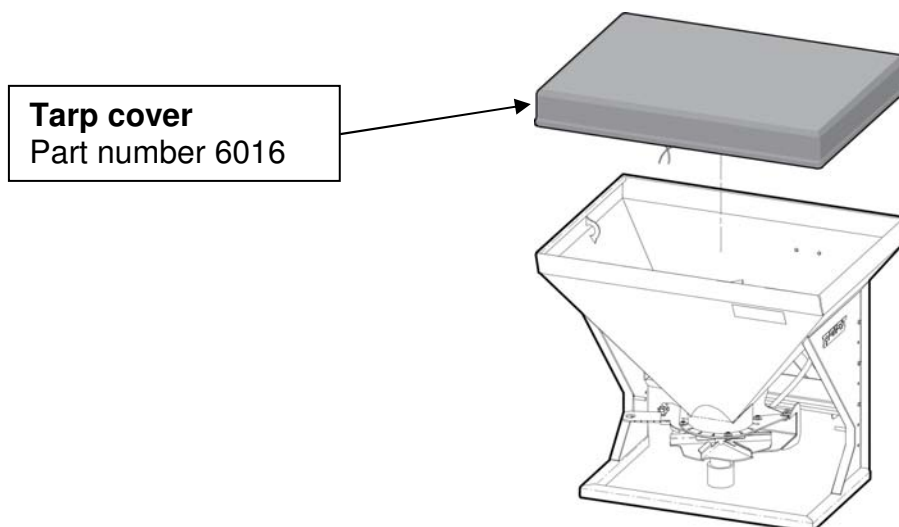

## **MAINTENANCE**

Refer to the General Safety Precautions, page 5 of this manual before performing any maintenance.

1. Always ensure the Broadcast Spreader is properly installed, the prime mover is positioned on a level surface with the park brake set
  2. Shut-off the engine and remove and retain the ignition key
  3. Chock the wheels to prevent movement and release residual hydraulic pressure
- At the beginning of each season, ensure that all fasteners are properly torqued, all safety guards are in place and that Operator's Manual is reviewed and understood
  - At the end of season, perform all maintenance and storage activities, always check for missing or damaged parts and that all gates function properly; repair as required

## **STORAGE**

1. Empty all product from hopper prior to removing it from the prime mover
2. Wash thoroughly before putting into storage
3. Inspect for loose, damaged or worn parts. Make needed adjustments, tighten loose parts and replace damaged and worn parts
4. Store in dry ventilated area properly supported to prevent tipping
5. Store with all hydraulic cylinder piston rod in a retracted position to prevent corrosion
6. Oiling the Broadcast Spreader before storage will ensure years of trouble free use

# PARTS

Note: some items shown are optional and may not be installed on your equipment.

## S100 Drive Mechanism Parts Drawing

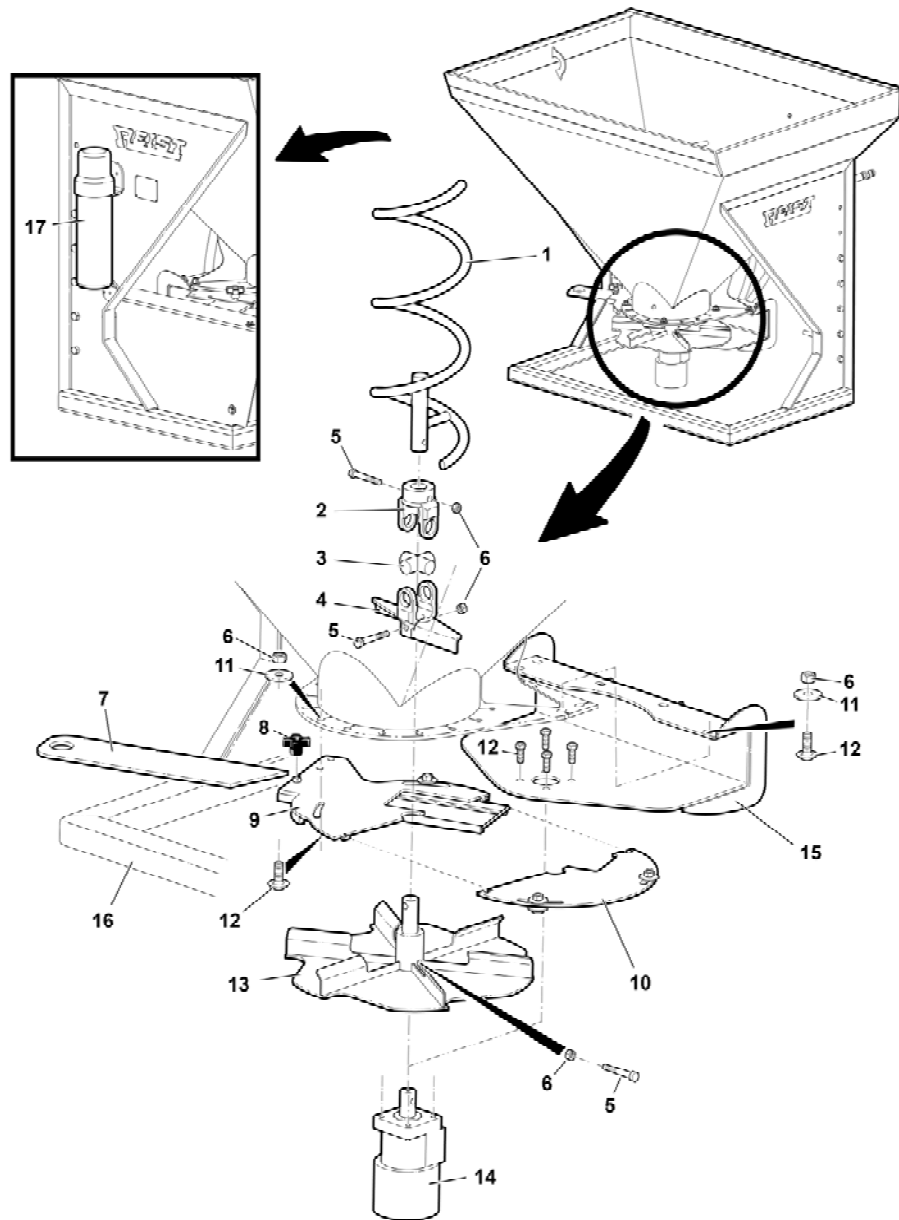

## S100 Drive Mechanism Parts List

Item	QTY	Part Number	Description
1	1	6017	Agitator
2	1	6018	10-4-93 Short Yoke
3	1	5-170	Cross
4	1	6015	Sweeper Yoke
5	3	38212	Hex Bolt
6	13	38N	Hex Nut
7	1	6009	Regulator Slider
8	1	134-022	Knob
9	1	6010	Regulator Plate
10	1	6012	Feeder Plate
11	20	38F	Washer
12	14	381	Hex Bolt
13	1	6008	Spinner
14	1	103-3365	Hyd Motor
15	1	6013	Motor Mount
16	1	6007	Spreader Weldment
17	1	67.222.000	Manual Holder

## S100 Spreader Plumbing Parts Drawing

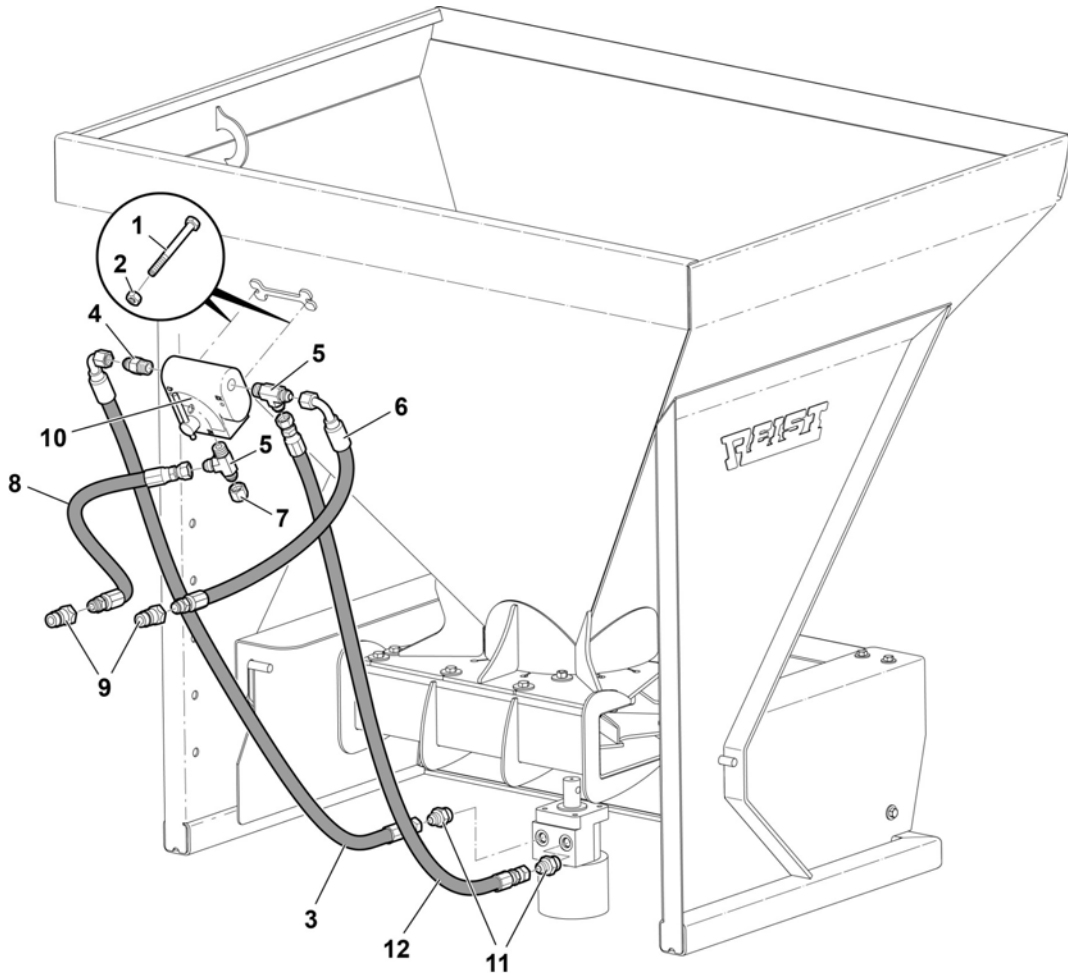

Optional Sidewalk Deflector shown installed

Item	QTY	Part Number	Description
1	2	14212	Hex Bolt
2	2	14N	Hex Nut
3	1	H24508-08U-668-08U-608-43	Hose – controlled flow
4	1	5205*8*8	Fitting
5	2	5755x8x8x8	Tee
6	1	H24508-08U-668-08U-608-73	Hose - tank
7	1	5129*8	Cap
8	1	H24508-08U-668-08U-108-621/2	Hose - pressure
9	2	8010-4	1/2 Male tip
10	1	FC51-1/2	Flow Control
11	2	5315*8*10	Fitting
12	1	H24508-08U-668-08U-608-381/2	Hose - return

## S100 Spreader Flow Control Parts Drawing

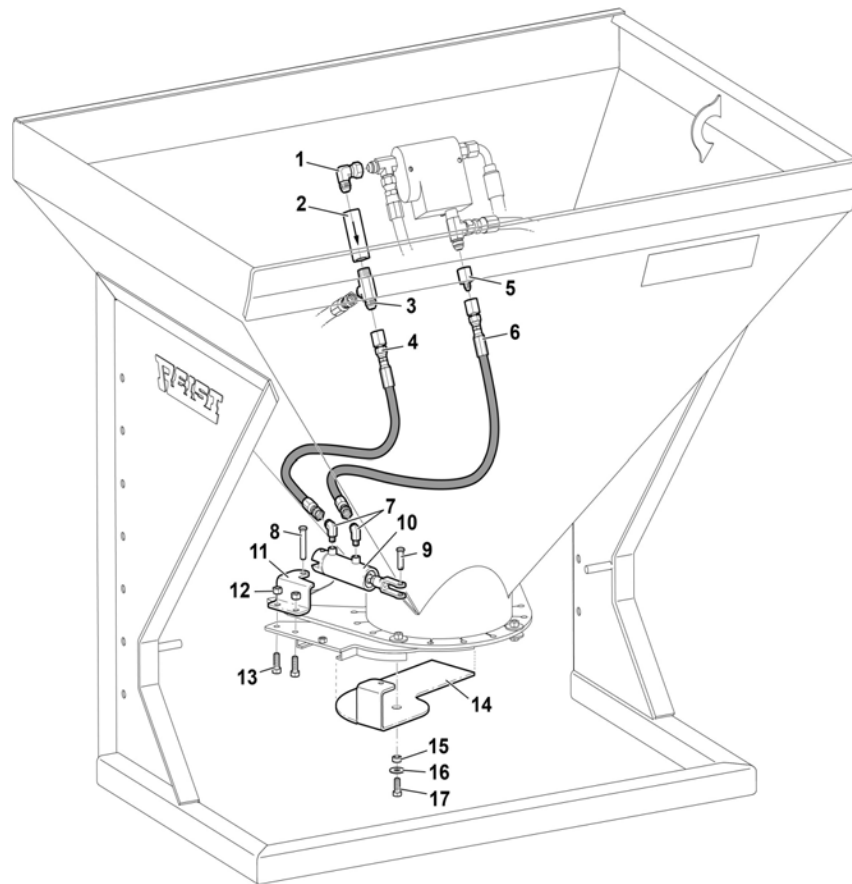

Item	QTY	Part Number	Description
1	1	2250-8-8S	JIC Swivel Elbow 90 8-8
2	1	VUS4	Check valve
3	1	5755x8x8x8	Tee
4	1	H24504-606-606-301/2	Hose retract
5	2	5015*8*6	Connector 4-6
6	1	H24504-606-606-301/2	Hose extend
7	2	5405*6*2	Elbow fitting
8	1	B-379	3/8x2 1/4 pin
9	1	38CP	3/8x1 1/4 pin
10	1	6027	Hydraulic cylinder
11	1	6002	Cylinder mount
12	2	38N	Hex nut
13	2	38*1	Hex bolt
14	1	6001	Shut off gate
15	1	6003	Bushing
16	1	38F	Plain washer
17	1	3834	Hex bolt

## S100 Hydraulic Unloading Hitch Parts Drawing

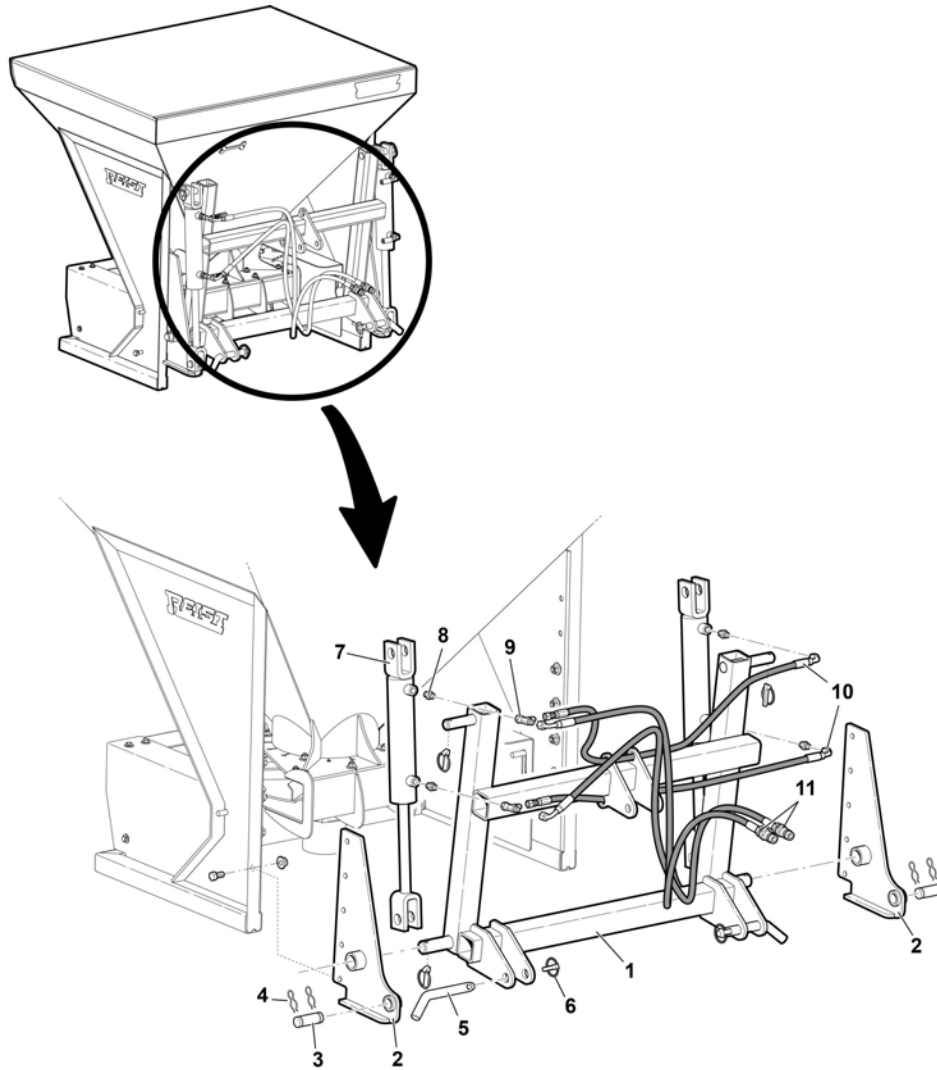

Item	QTY	Part Number	Description
1	1	6028	Power Frame
2	2	6029	Spreader PTL Side Plate
3	2	637855	Pin
4	4	637856	Hair Pin
5	2	CAT1-784	Cat 1 Arm Pin
6	4	385507	Lynch Pin
7	2	20FEM08-10	2x8x18-14 Cylinder
8	4	5315*6	Fitting
9	2	5700*6	Fitting
10	2	H24504-606-666-36-1/4	Cross hose
11	2	H24504-108-666-57	Hose
12	2	8010-4	1/2 Male tip

## S200 Spreader Drive Mechanism Parts Drawing

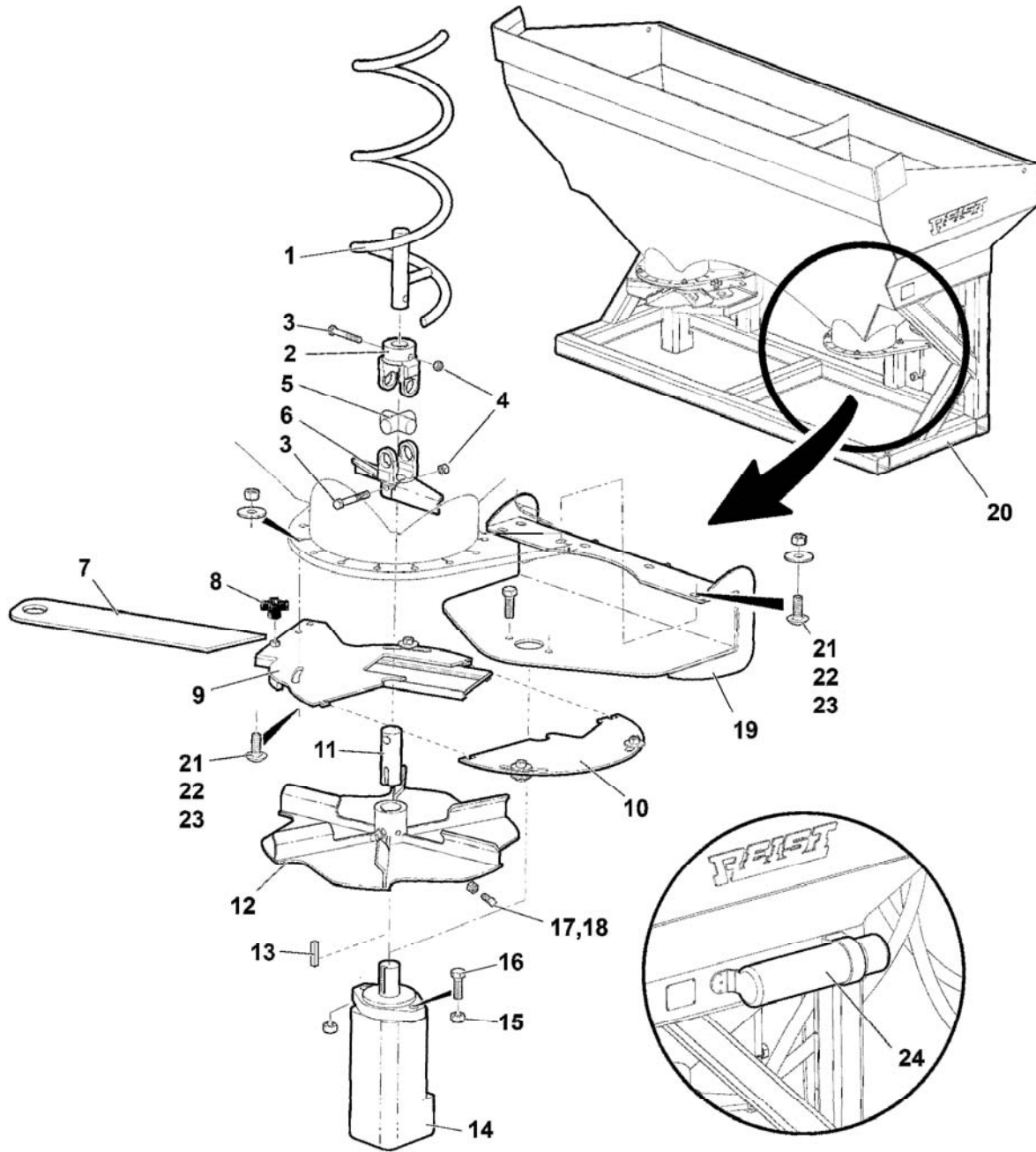

NOTE: Left and right side are determined when looking at spreader from mount side.

## S200 Spreader Drive Mechanism Parts List

Item	QTY per side	Part Number	Description
1	1	603004	Agitator - left
	1	603102 (not shown)	Agitator - right
2	1	6033	10-4-183 Short Yoke w/cross hole
3	1	12212	Hex Bolt
4	2	12N	Hex nut
5	1	5-170	Cross
6	1	603003	Sweeper yoke - left
	1	603103 (not shown)	Sweeper yoke - right
7	1	6009	Regulator slide
8	1	134-022	Knob
9	1	6010	Regulator plate - left
	1	603104	Regulator plate - right
10	1	6012	Feeder plate
11	1	Comes with #12	Keyed shaft
12	1	603001	Spinner - left
	1	603101	Spinner - right
13	1	516KS	Key
14	1	104-1026	Hydraulic motor
15	2	12N	Hex nut
16	2	12112	Hex bolt
17	1	381SH	Square Head setscrew
18	1	38N	Nut
19	1	603002	Motor mount
20	1	603200	Hopper and frame weldment
21	4	38F	Plain washer
22	4	38N	Hex nut
23	4	38114C	Carriage bolt
24	1	67.222.000	Manual holder

**NOTE:**

Left and right side are determined when looking at spreader from mount side. Quantities are for one spreader drive.

## S200 Spreader Drive Hydraulic Plumping Parts Drawing

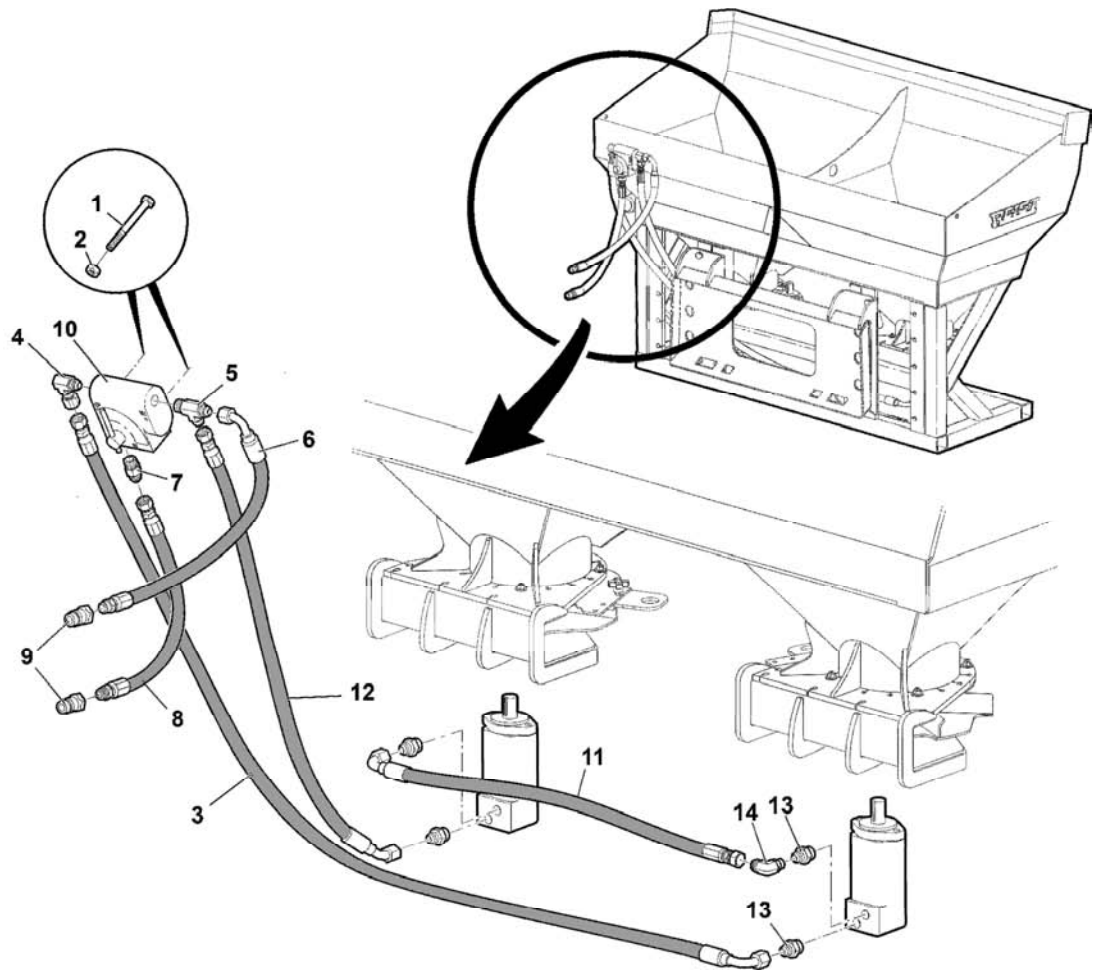

Item	QTY	Part Number	Description
1	2	14212	Hex Bolt
2	2	14N	Hex Nut
3	1	H14512-112-672-81	Hose control
4	1	9405*12*12	Elbow
5	1	5755x12	Tee
6	1	H14512-112-672-74	Hose tank
7	1	5205*12	Fitting
8	1	H14512-112-672-73	Hose pressure
9	1	8010-4	1/4 male tip
10	1	FC51-3/4	Flow Control
11	1	H14512-112-672-42	Hose cross line
12	1	H14512-112-672-45	Hose return
13	4	5315*12*10	Fitting
14	1	5515*12*10	90 Elbow fitting

## **WARRANTY INFORMATION**

All new REIST machinery is warranted to be free from defects in material or workmanship, which may cause failure under normal usage and service when used for the purpose intended for a period of 12 months. This warranty applies only to a new REIST product, there being no warranty of any nature in respect to new products that have been modified or altered, repaired, neglected, or used in any way, which, in the opinion of REIST adversely affects its performance.

In the event of failure of a part or parts, and upon inspection, REIST is satisfied that failure is due to defective material or workmanship within 12 calendar months from the date of delivery to an end user, such defective part or parts will be repaired or replaced by REIST Industries Inc. It is the responsibility of the buyer, at his expense, to transport the machine or equipment to the manufacturer service shop or to an authorized service depot or, alternatively, to reimburse REIST for any travel or transportation expense involved in fulfilling this warranty.

When requested by REIST, part or parts shall be returned for inspection, transportation prepaid, to a place designated by REIST. IN NO EVENT SHALL THE BUYER BE ENTITLED TO RECOVER FOR INCIDENTAL OR CONSEQUENTIAL DAMAGES, INCLUDING, BUT NOT LIMITED TO, LOSS OF PRODUCT, INCONVENIENCE, RENTAL OR REPLACEMENT EQUIPMENT, LOSS OF PROFIT, OR OTHER COMMERCIAL LOSS.

This warranty becomes void and null if the equipment is modified, breaks down as the result of an accident, is not operated according to manufacturer's recommendations, damaged by negligence or if maintenance has not been carried out as specified.

THIS WARRANTY IS NOT TRANSFERABLE

### ***Proof of Purchase – Retain for your records***

Date of Purchase (yyyy/mm/dd)		Model	Serial #	
Dealer Purchased From		City	State or Province	Country
First Name		Last Name	Phone Number (include area code)	
Address			State or Province	Country
City	Postal Code	<b>Return to: REIST Industries Inc.</b> <b>100 Union St., Elmira, Ontario, Canada N3B 2Z2 (519) 669-1501</b>		

Remove bottom section and return to REIST Industries within 30 days of purchase



### ***Proof of Purchase***

Date of Purchase (yyyy/mm/dd)		Model	Serial #	
Dealer Purchased From		City	State or Province	Country
First Name		Last Name	Phone Number (include area code)	
Address			State or Province	Country
City	Postal Code	<b>Return to: REIST Industries Inc.</b> <b>100 Union St., Elmira, Ontario, Canada N3B 2Z2 (519) 669-1501</b>		

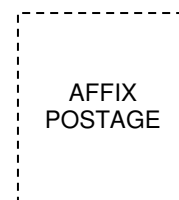

REIST Industries Inc.  
100 Union Street  
Elmira, Ontario, Canada  
N3B 2Z2